

# GE/GC864-QUAD V2 and GE864-GPS Hardware User Guide

1vv0300915 Rev.2 – 2011-06-15



## APPLICABILITY TABLE

PRODUCT
GE864-QUAD V2
GE864-GPS
GC864-QUAD V2
GC864-QUAD V2 With SIM Holder



**SPECIFICATIONS SUBJECT TO CHANGE WITHOut Notice**

**Notice**

While reasonable efforts have been made to assure the accuracy of this document, Telit assumes no liability resulting from any inaccuracies or omissions in this document, or from use of the information obtained herein. The information in this document has been carefully checked and is believed to be entirely reliable. However, no responsibility is assumed for inaccuracies or omissions. Telit reserves the right to make changes to any products described herein and reserves the right to revise this document and to make changes from time to time in content hereof with no obligation to notify any person of revisions or changes. Telit does not assume any liability arising out of the application or use of any product, software, or circuit described herein; neither does it convey license under its patent rights or the rights of others.

It is possible that this publication may contain references to, or information about Telit products (machines and programs), programming, or services that are not announced in your country. Such references or information must not be construed to mean that Telit intends to announce such Telit products, programming, or services in your country.

**Copyrights**

This instruction manual and the Telit products described in this instruction manual may be, include or describe copyrighted Telit material, such as computer programs stored in semiconductor memories or other media. Laws in the Italy and other countries preserve for Telit and its licensors certain exclusive rights for copyrighted material, including the exclusive right to copy, reproduce in any form, distribute and make derivative works of the copyrighted material. Accordingly, any copyrighted material of Telit and its licensors contained herein or in the Telit products described in this instruction manual may not be copied, reproduced, distributed, merged or modified in any manner without the express written permission of Telit. Furthermore, the purchase of Telit products shall not be deemed to grant either directly or by implication, estoppel, or otherwise, any license under the copyrights, patents or patent applications of Telit, as arises by operation of law in the sale of a product.

**Computer Software Copyrights**

The Telit and 3rd Party supplied Software (SW) products described in this instruction manual may include copyrighted Telit and other 3rd Party supplied computer programs stored in semiconductor memories or other media. Laws in the Italy and other countries preserve for Telit and other 3rd Party supplied SW certain exclusive rights for copyrighted computer programs, including the exclusive right to copy or reproduce in any form the copyrighted computer program. Accordingly, any copyrighted Telit or other 3rd Party supplied SW computer programs contained in the Telit products described in this instruction manual may not be copied (reverse engineered) or reproduced in any manner without the express written permission of Telit or the 3rd Party SW supplier. Furthermore, the purchase of Telit products shall not be deemed to grant either directly or by implication, estoppel, or otherwise, any license under the copyrights, patents or patent applications of Telit or other 3rd Party supplied



## GE/GC864-QUAD V2 and GE864-GPS Hardware User Guide

1vv0300915 Rev.2 – 2011-06-15

SW, except for the normal non-exclusive, royalty free license to use that arises by operation of law in the sale of a product.

### Usage and Disclosure Restrictions

#### License Agreements

The software described in this document is the property of Telit and its licensors. It is furnished by express license agreement only and may be used only in accordance with the terms of such an agreement.

#### Copyrighted Materials

Software and documentation are copyrighted materials. Making unauthorized copies is prohibited by law. No part of the software or documentation may be reproduced, transmitted, transcribed, stored in a retrieval system, or translated into any language or computer language, in any form or by any means, without prior written permission of Telit

#### High Risk Materials

Components, units, or third-party products used in the product described herein are NOT fault-tolerant and are NOT designed, manufactured, or intended for use as on-line control equipment in the following hazardous environments requiring fail-safe controls: the operation of Nuclear Facilities, Aircraft Navigation or Aircraft Communication Systems, Air Traffic Control, Life Support, or Weapons Systems ("High Risk Activities"). Telit and its supplier(s) specifically disclaim any expressed or implied warranty of fitness for such High Risk Activities.

#### Trademarks

TELIT and the Stylized T Logo are registered in Trademark Office. All other product or service names are the property of their respective owners.

Copyright © Telit Communications S.p.A. 2011.



## Contents

APPLICABILITY TABLE .....	2
<b>1. INTRODUCTION .....</b>	<b>8</b>
1.1. SCOPE .....	8
1.2. AUDIENCE.....	8
1.3. CONTACT INFORMATION, SUPPORT.....	8
1.4. DOCUMENT ORGANIZATION .....	8
1.5. TEXT CONVENTIONS .....	9
1.6. RELATED DOCUMENTS .....	10
<b>2. OVERVIEW.....</b>	<b>11</b>
<b>3. GE864-QUAD V2/GPS MECHANICAL DIMENSIONS .....</b>	<b>12</b>
3.1. GE864-QUAD V2/GPS .....	12
3.2. GC864-QUAD V2.....	13
3.3. MECHANICAL VIEW OF TELIT GC864-QUAD V2 WITH SIM HOLDER .....	14
3.4. GC864-QUAD V2 MODULE CONNECTIONS.....	14
<b>4. ELECTRICAL CONNECTIONS .....</b>	<b>15</b>
4.1. GE864-QUAD V2/GPS .....	15
4.1.1. PIN-OUT.....	15
4.1.2. BGA Balls Layout.....	20
4.2. GC864-QUAD V2.....	22
4.2.1. PIN-OUT.....	22
4.2.2. GC864-QUAD V2 Antenna Connector.....	25
<b>5. HARDWARE COMMANDS.....</b>	<b>26</b>
5.1. TURNING ON THE GE/GC864-QUAD V2 AND GE864-GPS .....	26
5.2. TURNING OFF THE GE/GC864-QUAD V2 AND GE864 GPS .....	29
5.3. HARDWARE UNCONDITIONAL RESTART .....	31
5.4. TURNING ON/OFF THE GPS (ONLY GE864-GPS).....	33
5.4.1. GPS Power-up.....	33
5.4.2. GPS Shutdown.....	34
<b>6. POWER SUPPLY.....</b>	<b>35</b>
6.1. POWER SUPPLY REQUIREMENTS .....	35
6.2. POWER CONSUMPTION.....	36
6.3. GENERAL DESIGN RULES.....	37
6.3.1. Electrical Design Guidelines.....	37
6.3.2. Battery Source Power Supply Design Guidelines .....	39
6.3.3. Thermal Design Guidelines.....	40
6.3.4. Power Supply PCB Layout Guidelines.....	41
6.3.5. Parameters for ATEX Applications .....	42
<b>7. ANTENNA.....</b>	<b>43</b>
7.1. GSM ANTENNA (GE864-QUAD V2/GPS AND GC864-QUAD V2) .....	43
7.1.1. GSM Antenna Requirements.....	43
7.1.2. GE864-QUAD V2/GPS GSM Antenna – PCB line Guidelines .....	44
7.1.3. GSM Antenna – Installation Guidelines .....	45
7.2. GPS ANTENNA (GE864-GPS ONLY).....	45



7.2.1.	<i>GPS Antenna Requirements</i> .....	45
7.2.2.	<i>Linear and Patch GPS Antenna</i> .....	45
7.2.3.	<i>GPS Antenna - PCB Line Guidelines</i> .....	45
7.2.4.	<i>GPS Antenna - Installation Guidelines</i> .....	46
<b>8.</b>	<b>LOGIC LEVEL SPECIFICATIONS</b> .....	<b>47</b>
8.1.	RESET SIGNAL .....	48
<b>9.</b>	<b>SERIAL PORTS</b> .....	<b>49</b>
9.1.	MODEM SERIAL PORT .....	49
9.2.	GE864-GPS SECONDARY PORTS .....	51
9.2.1.	<i>Modem Serial Port 2 (GPS Control)</i> .....	51
9.2.2.	<i>GPS Serial Port (NMEA)</i> .....	51
9.3.	RS232 LEVEL TRANSLATION .....	51
9.4.	5V UART LEVEL TRANSLATION .....	54
<b>10.</b>	<b>AUDIO SECTION OVERVIEW</b> .....	<b>55</b>
10.1.	SELECTION MODE.....	55
10.2.	ELECTRICAL CHARACTERISTICS .....	57
10.2.1.	<i>Input Lines Characteristics</i> .....	57
10.2.2.	<i>Output Lines Characteristics</i> .....	58
<b>11.</b>	<b>GENERAL PURPOSE I/O</b> .....	<b>60</b>
11.1.	GPIO LOGIC LEVELS .....	61
11.2.	USING A GPIO PAD AS INPUT .....	61
11.3.	USING A GPIO PAD AS OUTPUT .....	61
11.4.	USING THE RF TRANSMISSION CONTROL GPIO4.....	62
11.5.	USING THE RFTXMON OUTPUT GPIO5 .....	62
11.6.	USING THE ALARM OUTPUT GPIO6.....	62
11.7.	USING THE BUZZER OUTPUT GPIO7.....	63
11.8.	USING THE TEMPERATURE MONITOR FUNCTION .....	64
11.8.1.	<i>Short Description</i> .....	64
11.8.2.	<i>Allowed GPIO</i> .....	64
11.9.	INDICATION OF NETWORK SERVICE AVAILABILITY .....	65
11.10.	RTC BYPASS OUT .....	66
11.11.	EXTERNAL SIM HOLDER IMPLEMENTATION .....	66
11.12.	VAUX POWER OUTPUT (ONLY FOR GE864-GPS).....	66
<b>12.</b>	<b>GPS FEATURES (ONLY GE864-GPS)</b> .....	<b>67</b>
12.1.	GPS CONTROL .....	67
12.1.1.	<i>GSM Controlled Mode</i> .....	67
12.1.2.	<i>External Host Controlled Mode</i> .....	67
12.2.	PPS GPS OUTPUT .....	68
12.2.1.	<i>Description</i> .....	68
12.2.2.	<i>Pulse Characteristics</i> .....	68
<b>13.</b>	<b>DAC AND ADC CONVERTER</b> .....	<b>69</b>
13.1.	DAC CONVERTER.....	69
13.1.1.	<i>Description</i> .....	69
13.1.2.	<i>Enabling DAC</i> .....	69
13.1.3.	<i>Low Pass Filter Example</i> .....	70
13.2.	ADC CONVERTER.....	70



## GE/GC864-QUAD V2 and GE864-GPS Hardware User Guide

1vv0300915 Rev.2 – 2011-06-15

13.2.1.	<i>Description</i> .....	70
13.2.2.	<i>Using ADC Converter</i> .....	71
<b>14.</b>	<b>ASSEMBLY THE GE/GC864-QUAD V2 AND GE864-GPS ON THE BOARD</b> .....	<b>72</b>
14.1.	ASSEMBLY THE GE864-QUAD V2.....	72
14.1.1.	<i>Recommended foot print for the application</i> .....	72
14.1.2.	<i>Stencil</i> .....	73
14.1.3.	<i>PCB pad design</i> .....	73
14.1.4.	<i>Solder paste</i> .....	74
14.1.5.	<i>GE864-QUAD V2/GPS Solder reflow</i> .....	74
14.2.	ASSEMBLY THE GC864-QUAD V2.....	76
14.3.	DEBUG OF THE GE/GC864-QUAD V2 AND GE864-GPS IN PRODUCTION.....	77
<b>15.</b>	<b>PACKING SYSTEM</b> .....	<b>78</b>
15.1.	GE864-QUAD V2/GPS PACKAGING.....	78
15.1.1.	<i>Moisture sensibility</i> .....	79
15.1.2.	<i>GE864 orientation on the tray</i> .....	79
15.2.	GE/GC864-QUAD V2 AND GE864-GPS PACKAGING.....	80
<b>16.</b>	<b>CONFORMITY ASSESSMENT ISSUES</b> .....	<b>81</b>
<b>17.</b>	<b>SAFETY RECOMMENDATIONS</b> .....	<b>83</b>
<b>18.</b>	<b>DOCUMENT HISTORY</b> .....	<b>84</b>



## 1. Introduction

### 1.1. Scope

The aim of this document is the description of some hardware solutions useful for developing a product with the Telit GE/GC864-QUAD V2 and GE864-GPS modules.

### 1.2. Audience

This document is intended for Telit customers, who are integrators, about to implement their applications using our GE/GC864-QUAD V2 and GE864-GPS modules.

### 1.3. Contact Information, Support

For general contact, technical support, to report documentation errors and to order manuals, contact Telit Technical Support Center (TTSC) at:

[TS-EMEA@telit.com](mailto:TS-EMEA@telit.com)  
[TS-NORTHAMERICA@telit.com](mailto:TS-NORTHAMERICA@telit.com)  
[TS-LATINAMERICA@telit.com](mailto:TS-LATINAMERICA@telit.com)  
[TS-APAC@telit.com](mailto:TS-APAC@telit.com)

Alternatively, use:

<http://www.telit.com/en/products/technical-support-center/contact.php>

For detailed information about where you can buy the Telit modules or for recommendations on accessories and components visit:

<http://www.telit.com>

To register for product news and announcements or for product questions contact Telit's Technical Support Center (TTSC).

Our aim is to make this guide as helpful as possible. Keep us informed of your comments and suggestions for improvements.

Telit appreciates feedback from the users of our information.

### 1.4. Document Organization

This document contains the following chapters:

[Chapter 1: "Introduction"](#) provides a scope for this document, target audience, contact and support information, and text conventions.

[Chapter 2: "Overview"](#) provides an overview of the document.

[Chapter 3: "Mechanical Dimensions"](#)





[Chapter 4: “Electrical Connections”](#) deals with the pin out configuration and layout.

[Chapter 5: “Hardware Commands”](#) How to operate on the module via hardware.

[Chapter 6: “Power supply”](#) Power supply requirements and general design rules.

[Chapter 7: “Antenna”](#) The antenna connection and board layout design are the most important parts in the full product design

[Chapter 8: “Logic Level specifications”](#) Specific values adopted in the implementation of logic levels for the modules.

[Chapter 9: “Serial ports”](#) The serial port on the modules is the core of the interface between the module and OEM hardware

[Chapter 10: “Audio Section overview”](#) Refers to the audio blocks of the Base Band Chip of the modules.

[Chapter 11: “General Purpose I/O”](#) How the general purpose I/O pads can be configured.

[Chapter 12: “GPS Features \(GE864-GPS only\)”](#)

[Chapter 13: “DAC and ADC Converter”](#) How the DAC and ADC pads can be configured.

[Chapter 14: “Mounting the GE/GC864-QUAD V2 AND GE864-GPS on the application board”](#) Recommendations and specifics on how to mount the modules on the user’s board.

[Chapter 15: “Packing System”](#): deals about the GE/GC864 family packaging systems

[Chapter 16: “Conformity Assessment Issues”](#): refer the compliance with reference standards

[Chapter 17: “Safety Recommendations”](#): contains recommendations for proper and safe user

[Chapter 18: “Document History ”](#):

## 1.5. Text Conventions



***Danger – This information MUST be followed or catastrophic equipment failure or bodily injury may occur.***



***Caution or Warning – Alerts the user to important points about integrating the module, if these points are not followed, the module and end user equipment may fail or malfunction.***



**Tip or Information – Provides advice and suggestions that may be useful when integrating the module.**



All dates are in ISO 8601 format, i.e. YYYY-MM-DD.

## 1.6. Related Documents

- Telit's GSM/GPRS Family Software User Guide, 1vv0300784
- Audio settings application note , 80000NT10007a
- Digital voice Interface Application Note, 80000NT10004a
- Product description, 80331ST10074a
- SIM Holder Design Guides, 80000NT10001a
- AT Commands Reference Guide, 80000ST10025a
- Telit EVK2 User Guide, 1vv0300704



## 2. Overview

In this document all the basic functions of a mobile phone are taken into account; for each one of them a proper hardware solution is suggested and eventually the wrong solutions and common errors to be avoided are evidenced. Obviously this document cannot embrace the whole hardware solutions and products that may be designed. The wrong solutions to be avoided shall be considered as mandatory, while the suggested hardware configurations shall not be considered mandatory, instead the information given shall be used as a guide and a starting point for properly developing your product with the Telit GE864-QUAD V2/GPS and/or GC864-QUAD V2 modules. For further hardware details that may not be explained in this document refer to the Telit GE864-QUAD V2/GPS and GC864-QUAD V2 Product Description document where all the hardware information is reported.



---

### NOTICE:

(EN) The integration of the GE864-QUAD V2/GPS and GC864-QUAD V2 cellular modules within user application shall be done according to the design rules described in this manual.

---

The information presented in this document is believed to be accurate and reliable. However, no responsibility is assumed by Telit Communications S.p.A. for its use, or any infringement of patents or other rights of third parties which may result from its use. No license is granted by implication or otherwise under any patent rights of Telit Communications S.p.A. other than for circuitry embodied in Telit products. This document is subject to change without notice.



### 3. GE864-QUAD V2/GPS Mechanical Dimensions

#### 3.1. GE864-QUAD V2/GPS

The Telit GE864-QUAD V2/GPS modules overall dimensions are:

- Length: 30 mm
- Width: 30 mm
- Thickness : 2,9 mm
- Weight: 4.2g

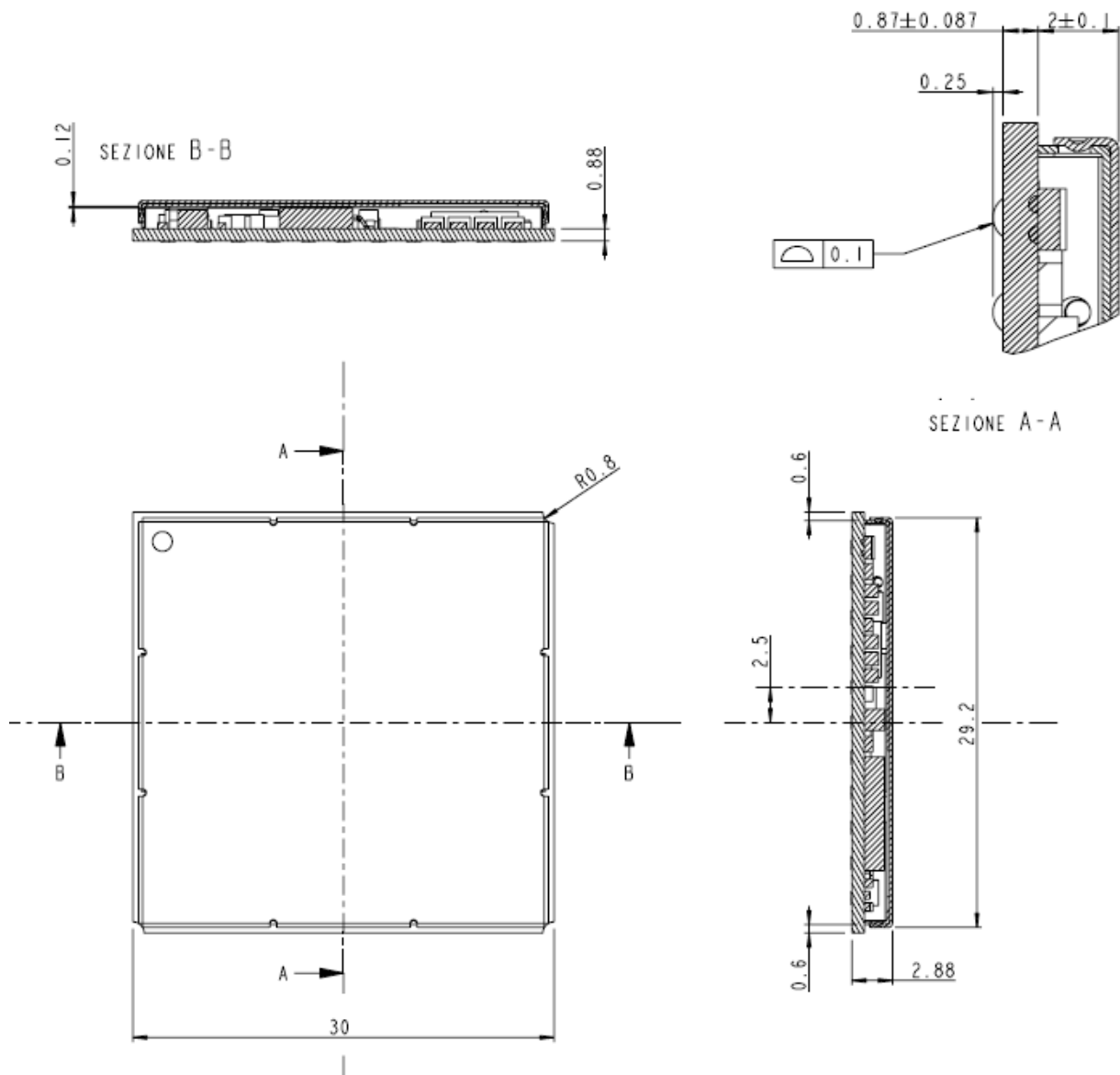

## 3.2. GC864-QUAD V2

The Telit GC864-QUAD V2 module overall dimensions are:

- Length: 36.2 mm
- Width: 30 mm
- Thickness: 3.2 mm
- Weight: 4.8g

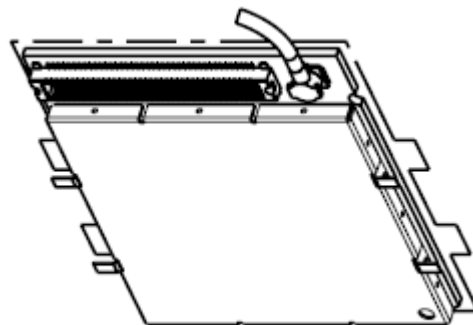
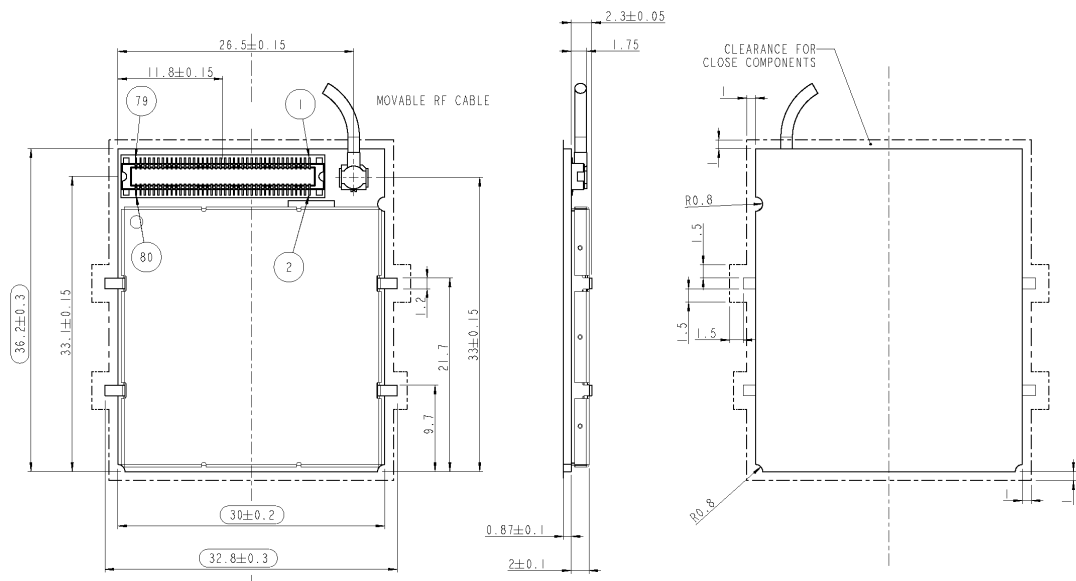

### 3.3. Mechanical View of Telit GC864-QUAD V2 with SIM Holder

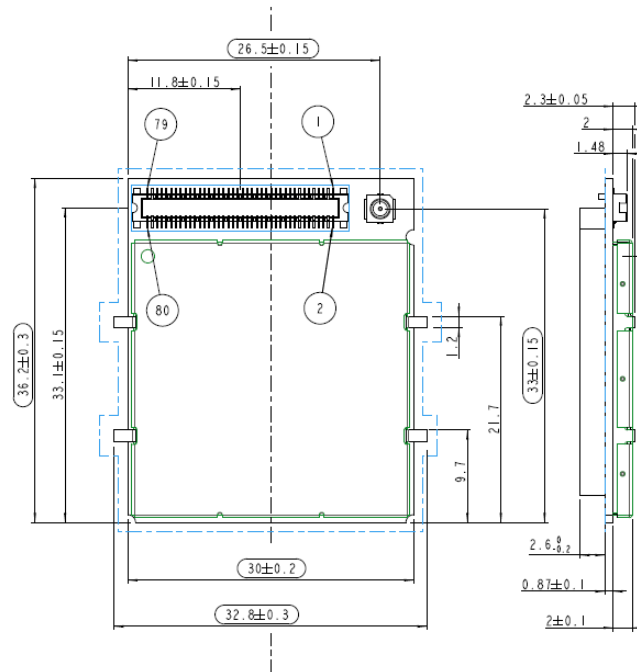

### 3.4. GC864-QUAD V2 Module Connections

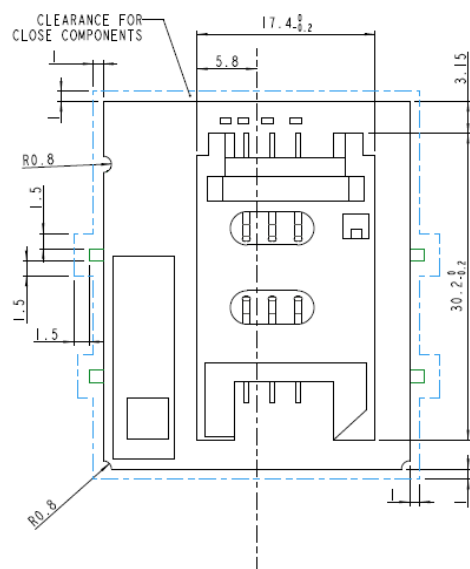

## 4. Electrical Connections

### 4.1. GE864-QUAD V2/GPS

#### 4.1.1. PIN-OUT

The GE864-QUAD V2/GPS use 11x11 array BGA technology connection

Ball	Signal	I/O	Function	Internal PULL UP	Type
<b>Audio</b>					
F9	AXE	I	Handsfree switching	100K	CMOS 2.8V
G8	MIC_HF+	AI	Handsfree mic. input; phase +, nom. level 3mVrms		Audio
G9	MIC_MT-	AI	Handset mic.signal input; phase-, nom. level 50mVrms		Audio
G10	EAR_MT+	AO	Handset earphone signal output, phase +		Audio
J8	MIC_MT+	AI	Handset mic.signal input; phase+, nom. level 50mVrms		Audio
J9	MIC_HF-	AI	Handsfree mic.input; phase -, nom. level 3mVrms		Audio
J10	EAR_HF-	AO	Handsfree ear output, phase -		Audio
H9	EAR_MT-	AO	Handset earphone signal output, phase -		Audio
H10	EAR_HF+	AO	Handsfree ear output, phase +		Audio
<b>SIM card interface</b>					
C10	SIMCLK	O	External SIM signal – Clock		1,8 / 3V
C11	SIMIN	I	External SIM signal - Presence (active low)	Pull up 47K	1,8 / 3V
D4	SIMVCC	-	External SIM signal – Power supply for the SIM		1,8 / 3V
D10	SIMIO	I/O	External SIM signal - Data I/O	Pull up 4.7K	1,8 / 3V
E9	SIMRST	O	External SIM signal – Reset		1,8 / 3V
<b>Auxiliary UART/Trace</b>					
D11	TX_AUX	O	Auxiliary UART (TX Data to DTE)		CMOS 2.8V
F10	RX_AUX	I	Auxiliary UART (RX Data from DTE)		CMOS 2.8V
H4	SERVICE	I	Service pin shall be used to upgrade the module from ASC1 (RX_TRACE, TX_TRACE). The pin shall be tied low to enable the feature only in case of a SW Update activity. It is required, for debug purpose, to be connected to a test pad on the final application.		CMOS 2.8V
<b>Prog. / Data + HW Flow Control</b>					
B6	C125/RING	O	Output for Ring indicator signal (RI) to DTE		CMOS 2.8V
B7	C108/DTR	I	Input for Data terminal ready signal (DTR) from DTE		CMOS 2.8V
D9	C109/DCD	O	Output for Data carrier detect signal (DCD) to DTE		CMOS 2.8V
E7	C103/TXD	I	Serial data input (TXD) from DTE		CMOS 2.8V
E11	C107/DSR	O	Output for Data set ready signal (DSR) to DTE		CMOS 2.8V
F7	C105/RTS	I	Input for Request to send signal (RTS) from DTE		CMOS 2.8V
F6	C106/CTS	O	Output for Clear to send signal (CTS) to DTE		CMOS 2.8V

## GE/GC864-QUAD V2 and GE864-GPS Hardware User Guide

1vv0300915 Rev.2 – 2011-06-15

Ball	Signal	I/O	Function	Internal PULL UP	Type
H8	C104/RXD	O	Serial data output to DTE		CMOS 2.8V
<b>DAC and ADC</b>					
C7	DAC_OUT	AO	Digital/Analog converter output		D/A
J11	ADC_IN1	AI	Analog/Digital converter input		A/D
H11	ADC_IN2	AI	Analog/Digital converter input		A/D
<b>Miscellaneous Functions</b>					
A2	RESET#	I	Reset input		
D8	STAT_LED	O	Status indicator led		CMOS 1.8V
E2	VRTC	AO	VRTC		Power
J5	ON_OFF#	I	Input command for switching power ON or OFF (toggle command). The pulse to be sent to the GE864-QUAD V2 must be equal or greater than 1 second.	Pull up 47K	Pull up to VBATT
L8	PWRMON	O	PWRMON		CMOS 2.8V
L4	GSM Antenna	O	Antenna output – 50 ohm		RF
D5	VAUX <sup>(1)</sup>	AO	Auxiliary 2.8V Output		Power
<b>Telit GPIO / DVI</b>					
C1	GPIO_01	I/O	GPIO_01		CMOS 2.8V
E6	GPIO_02 / JDR	I/O	GPIO_02 / JDR		CMOS 2.8V
C2	GPIO_03	I/O	GPIO_03		CMOS 2.8V
B3	GPIO_04 / TX_DISABLE	I/O	GPIO_04 / TX_DISABLE		CMOS 2.8V
K8	GPIO_05 / RFTXMON	I/O	Telit GPIO05 Configurable GPIO / Transmitter ON monitor		CMOS 2.8V
B5	GPIO_06 / ALARM	I/O	Telit GPIO06 Configurable GPIO / ALARM		CMOS 2.8V
L9	GPIO_07 / BUZZER	I/O	Telit GPIO07 Configurable GPIO / Buzzer		CMOS 2.8V
K11	GPIO_08	I/O	GPIO_08		CMOS 2.8V
C9	GPIO_09	I/O	GPIO_09		CMOS 2.8V
H3	GPIO_10 / DVI_TX	I/O	GPIO_10 / DVI_TX- DVI audio*		CMOS 2.8V
K7	DVI_RX	I/O	DVI_RX - DVI audio*		CMOS 2.8V
D7	DVI_CLK	I/O	DVI_CLK - DVI audio*		CMOS 2.8V
H5	DVI_WA0	I/O	DVI_WA0 - DVI audio*		CMOS 2.8V
<b>GPS<sup>(1)</sup> (only for GE864-GPS)</b>					
A7	GPS_EXT_LNA_EN <sup>(1)</sup>	O	External LNA Enable		CMOS 1.8V (GPS)
C8	GPS_PPS <sup>(1)</sup>	O	Pulse Per Second		CMOS 1.8V (GPS)
E10	GPS_RX <sup>(1)</sup>	I	Serial Data Input		CMOS 2.8V (GPS)
F8	GPS_TX <sup>(1)</sup>	O	Serial Data Output		CMOS 2.8V (GPS)
G2	GPS_WAKEUP <sup>(1)</sup>	O	Wake up output		CMOS 2.8V (GPS)
J4	GPS_ON_OFF <sup>(1)</sup>	I	GPS Power Control		CMOS 1.8V (GPS)
A10	GPS Antenna <sup>(1)</sup>	O	Antenna output – 50 ohm		RF
<b>Power Supply</b>					
J1	VBATT	-	Main power supply		Power
K1	VBATT	-	Main power supply		Power
J2	VBATT	-	Main power supply		Power
K2	VBATT	-	Main power supply		Power
A1	GND	-	Ground		Power
A11	GND	-	Ground		Power





**GE/GC864-QUAD V2 and GE864-GPS Hardware User Guide**  
1vv0300915 Rev.2 – 2011-06-15

Ball	Signal	I/O	Function	Internal PULL UP	Type
D6	GND	-	Ground		Power
F1	GND	-	Ground		Power
F11	GND	-	Ground		Power
H1	GND	-	Ground		Power
H2	GND	-	Ground		Power
J3	GND	-	Ground		Power
K3	GND	-	Ground		Power
K4	GND	-	Ground		Power
K5	GND	-	Ground		Power
K6	GND	-	Ground		Power
L1	GND	-	Ground		Power
L2	GND	-	Ground		Power
L3	GND	-	Ground		Power
L6	GND	-	Ground		Power
L11	GND	-	Ground		Power
A8	GND <sup>(1)</sup>	-	Ground <sup>(1)</sup>		Power
B8	GND <sup>(1)</sup>	-	Ground <sup>(1)</sup>		Power
B9	GND <sup>(1)</sup>	-	Ground <sup>(1)</sup>		Power
B10	GND <sup>(1)</sup>	-	Ground <sup>(1)</sup>		Power
B11	GND <sup>(1)</sup>	-	Ground <sup>(1)</sup>		Power
<b>RESERVED</b>					
A3	-	-	Reserved		
A4	-	-	Reserved		
A5	-	-	Reserved		
A6	-	-	Reserved		
A9	-	-	Reserved		
B1	-	-	Reserved		
B2	-	-	Reserved		
B4	-	-	Reserved		
C3	-	-	Reserved		
C4	-	-	Reserved		
C5 <sup>(2)</sup>	-	-	Reserved <sup>(2)</sup>		
C6	-	-	Reserved		
D1	-	-	Reserved		
D2	-	-	Reserved		
D3	-	-	Reserved		
E1	-	-	Reserved		
E3	-	-	Reserved		
E4	-	-	Reserved		
E5	-	-	Reserved		
E8	-	-	Reserved		
F2	-	-	Reserved		
F3	-	-	Reserved		



Ball	Signal	I/O	Function	Internal PULL UP	Type
F4	-	-	Reserved		
F5	-	-	Reserved		
G1	-	-	Reserved		
G3	-	-	Reserved		
G4	-	-	Reserved		
G5	-	-	Reserved		
G6 <sup>(2)</sup>	-	-	Reserved <sup>(2)</sup>		
G7	-	-	Reserved		
G11	-	-	Reserved		
H6	-	-	Reserved		
H7	-	-	Reserved		
J6	-	-	Reserved		
J7	-	-	Reserved		
K9	-	-	Reserved		
K10	-	-	Reserved		
L5	-	-	Reserved		
L7	-	-	Reserved		
L10	-	-	Reserved		

\* Ref. to Digital Voice Interface Application Note 80000NT10004a.

(1) Available only on GE864-GPS (in case of GE864-QUAD it has to be considered RESERVED)



**NOTE:**

The GE864-QUAD V2/GPS Modules has one DVI port on the system.



**NOTE:**

Reserved pins must not be connected.

(2) Only for GE864-GPS connect the G6 ball (although declared reserved) **must be** connected to ground (suggested through a 0 ohm resistor) and C6 ball (although declared reserved) **must be** connected to VAUX (Ball D5) through a pull up resistor (e.g. 47K).



**NOTE:**

RTS must be connected to the GND (on the module side) if flow control is not used.





**NOTE:**

If not used, almost all pins must be left disconnected. The only exceptions are the following pins:

(1) Available only on GE864-GPS (in case of GE864-QUAD V2 it has to be considered RESERVED)



**NOTE:**

Only for GE864-GPS, **do not leave** the GPS\_ON\_OFF (ball J4) input pin floating. It's suggested to connect a pull-down (e.g.: 100k).

Ball	Signal	Function
J1, J2, K1, K2	VBATT	Main power supply
A1, A8 <sup>(1)</sup> , A11, B8 <sup>(1)</sup> , B9 <sup>(1)</sup> , B10 <sup>(1)</sup> , B11 <sup>(1)</sup> , D6, F1, F11, H1, H2, J3, K3, K4, K5, K6, L1, L2, L3, L6, L11	GND	Ground
E7	C103/TXD	Serial data input (TXD) from DTE
H8	C104/RXD	Serial data output to DTE
F7	C105/RTS	Input for Request to send signal (RTS) from DTE
J5	ON/OFF#	Input command for switching power ON or OFF (toggle command).
A2	RESET#	Reset input
F10	RX_TRACE	RX Data for debug monitor
D11	TX_TRACE	TX Data for debug monitor
H4	SERVICE	SERVICE connection
B7	DTR	Input for Data terminal ready signal (DTR) from DTE
J4 <sup>(1)</sup>	GPS_ON_OFF	GPS Power Control
G2 <sup>(1)</sup>	GPS_WAKEUP	GPS Wake up output
E10 <sup>(1)</sup>	GPS_RX	GPS Serial data input
F8 <sup>(1)</sup>	GPS_TX	GPS Serial data output



### 4.1.2. BGA Balls Layout

TOP VIEW

	A	B	C	D	E	F	G	H	J	K	L
1	GND	-	GPIO_01	-	-	GND	-	GND	VBATT	VBATT	GND
2	RESET*	-	GPIO_03	-	VRTC	-	GPS_WAK EUP <sup>1</sup>	GND	VBATT	VBATT	GND
3	-	GPIO_04 / TX_DISABLE	-	-	-	-	-	GPIO_10 / DVI_TX	GND	GND	GND
4	-	-	-	SIMVCC	-	-	-	SERVICE	GPS_ON_O FF <sup>1</sup>	GND	GSM Antenna
5	-	GPIO_06 / ALARM	-	VAUX <sup>1</sup>	-	-	-	DVI_WA0	ON_OFF*	GND	-
6	-	C125 / RING	-	GND	GPIO_02 / JDR	C106 / CTS	-	-	-	GND	GND
7	GPS_EXT LNA_EN <sup>3</sup>	C108 / DTR	DAC_OUT	DVI_CLK	C103 / TXD	C105 / RTS	-	-	-	DVI_RX	-
8	GND <sup>1</sup>	GND <sup>1</sup>	GPS_PPS <sup>1</sup>	STAD_ LED	-	GPS_TX <sup>1</sup>	MIC_HF+	C104 / RXD	MIC_MT+	GPIO_05 / RFTXMON	PWRMON
9	-	GND <sup>1</sup>	GPIO_09	C109 / DCD	SIMRST	AXE	MIC_MT-	EAR_MT-	MIC_HF-	-	GPIO_07 / BUZZER
10	GPS Antenna <sup>1</sup>	GND <sup>1</sup>	SIMCLK	SIMIO	GPS_RX <sup>1</sup>	RX_AUX	EAR_MT+	EAR_HF+	EAR_HF-	-	-
11	GND <sup>1</sup>	GND <sup>1</sup>	SIMIN	TX_AUX	C107 / DSR	GND	-	ADC_IN2	ADC_IN1	GPIO_08	GND

(1) Available only on GE864-GPS (in case of GE864-QUAD V2 it has to be considered RESERVED)



**GE/GC864-QUAD V2 and GE864-GPS Hardware User Guide**  
 1vv0300915 Rev.2 – 2011-06-15

	AUDIO Signals balls
	SIM CARD interface balls
	AUX UART&SERVICE Signals balls
	Prog. / data + Hw Flow Control signals balls
	ADC signals balls
	MISCELLANEOUS functions signals balls
	TELIT GPIO balls
	GPS balls
	POWER SUPPLY VBATT balls
	POWER SUPPLY GND balls
	RESERVED



## 4.2. GC864-QUAD V2

### 4.2.1. PIN-OUT

The GC864-QUAD V2 uses an 80 pin Molex p.n. 53949-0878 male connector for the connections with the external applications. This connector matches the 54150-0878 models.

Pin	Signal	I/O	Function	Internal Pull up	Type
<b>Power Supply</b>					
1	VBATT	-	Main power supply		Power
2	VBATT	-	Main power supply		Power
3	VBATT	-	Main power supply		Power
4	VBATT	-	Main power supply		Power
5	GND	-	Ground		Power
6	GND	-	Ground		Power
7	GND	-	Ground		Power
<b>Audio</b>					
8	AXE	I	Handsfree switching	100K $\Omega$	CMOS 2.8V
9	EAR_HF+	AO	Handsfree ear output, phase +		Audio
10	EAR_HF-	AO	Handsfree ear output, phase -		Audio
11	EAR_MT+	AO	Handset earphone signal output, phase +		Audio
12	EAR_MT-	AO	Handset earphone signal output, phase -		Audio
13	MIC_HF+	AI	Handsfree microphone input; phase		Audio
14	MIC_HF-	AI	Handsfree microphone input; phase		Audio
15	MIC_MT+	AI	Handset microphone signal input; phase+		Audio
16	MIC_MT-	AI	Handset microphone signal input; phase-		Audio
<b>SIM Card Interface</b>					
18 <sup>1</sup>	SIMVCC	-	External SIM signal – Power supply for the SIM		1.8 / 3V
19	SIMRST	O	External SIM signal – Reset		1.8 / 3V
20	SIMIO	I/O	External SIM signal - Data I/O		1.8 / 3V
21	SIMIN	I	External SIM signal - Presence (active low)	47K $\Omega$	1.8 / 3V
22	SIMCLK	O	External SIM signal – Clock		1.8 / 3V
<b>Trace</b>					
23	RX_TRACE	I	RX Data for debug monitor		CMOS 2.8V
24	TX_TRACE	O	TX Data for debug monitor		CMOS 2.8V
47	SERVICE	I	Service pin shall be used to upgrade the module from ASC1 (RX_TRACE, TX_TRACE). The pin shall be tied low to enable the feature only in case of a SW Update activity. It is required, for debug purpose, to be connected to a test pad on the final application.	2.2K $\Omega$	CMOS 2.8V
<b>Prog. / Data + Hw Flow Control</b>					

<sup>1</sup> On this line a maximum of 10nF bypass capacitor is allowed



## GE/GC864-QUAD V2 and GE864-GPS Hardware User Guide

1vv0300915 Rev.2 – 2011-06-15

Pin	Signal	I/O	Function	Internal Pull up	Type
25	C103/TXD	I	Serial data input (TXD) from DTE		CMOS 2.8V
26	C104/RXD	O	Serial data output (RXD) to DTE		CMOS 2.8V
27	C107/DSR	O	Output for Data set ready signal (DSR) to DTE		CMOS 2.8V
28	C106/CTS	O	Output for Clear to send signal (CTS) to DTE		CMOS 2.8V
29	C108/DTR	I	Input for Data terminal ready signal (DTR) from DTE		CMOS 2.8V
30	C125/RING	O	Output for Ring indicator signal (RI) to DTE		CMOS 2.8V
31	C105/RTS	I	Input for Request to send signal (RTS) from DTE		CMOS 2.8V
32	C109/DCD	O	Output for Data carrier detect signal (DCD) to DTE		CMOS 2.8V
DAC and ADC					
37	ADC_IN1	AI	Analog/Digital converter input		A/D
38	ADC_IN2	AI	Analog/Digital converter input		A/D
39	ADC_IN3	AI	Analog/Digital converter input		A/D
40	DAC_OUT	AO	Digital/Analog converter output		D/A
Miscellaneous Functions					
45	STAT_LED	O	Status indicator led		CMOS 1.8V
46	GND	-	Ground		Ground
49	PWRMON	O	Power ON Monitor		CMOS 2.8V
53	ON/OFF*	I	Input command for switching power ON or OFF (toggle command). The pulse to be sent to the GC864-QUAD V2 must be equal or greater than 1 second.	47K $\Omega$	Pull up to VBATT
54	RESET*	I	Reset input		
55	VRTC	AO	VRTC Backup capacitor		Power
Telit GPIO / DVI					
36	DVI_CLK	-	DVI_CLK (Digital Voice Interface Clock)		CMOS 2.8V
59	TGPIO_04/TXCNTRL	I/O	Telit GPIO4 Configurable GPIO / RF Transmission Control		CMOS 2.8V
63	TGPIO_10/DVI_TX	I/O	Telit GPIO10 Configurable GPIO / DVI_TX (Digital Voice Interface)		CMOS 2.8V
65	DVI_RX	I/O	DVI_RX (Digital Voice Interface)		CMOS 2.8V
66	TGPIO_03	I/O	Telit GPIO3 Configurable GPIO		CMOS 2.8V
67	TGPIO_08	I/O	Telit GPIO8 Configurable GPIO		CMOS 2.8V
68	TGPIO_06 / ALARM	I/O	Telit GPIO6 Configurable GPIO / ALARM		CMOS 2.8V
70	TGPIO_01	I/O	Telit GPIO1 Configurable GPIO		CMOS 2.8V
71	DVI_WAO	I/O	DVI_WAO (Digital Voice Interface)		CMOS 2.8V
73	TGPIO_07 / BUZZER	I/O	Telit GPIO7 Configurable GPIO / Buzzer		CMOS 2.8V
74	TGPIO_02 / JDR	I/O	Telit GPIO02 I/O pin / Jammer detect report		CMOS 2.8V
76	TGPIO_09	I/O	Telit GPIO9 Configurable GPIO		CMOS 2.8V
78	TGPIO_05/ RFTXMON	I/O	Telit GPIO05 Configurable GPIO / Transmitter ON monitor		CMOS 2.8V
RESERVED					
17	Reserved	-			
33	Reserved	-			



Pin	Signal	I/O	Function	Internal Pull up	Type
34	Reserved	-			
35	Reserved	-			
41	Reserved	-			
42	Reserved	-			
43	Reserved	-			
44	Reserved	-			
48	Reserved	-			
50	Reserved	-			
51	Reserved	-			
52	Reserved	-			
56	Reserved	-			
57	Reserved	-			
58	Reserved	-			
60	Reserved	-			
61	Reserved	-			
62	Reserved	-			
64	Reserved	-			
69	Reserved	-			
72	Reserved	-			
75	Reserved	-			
77	Reserved	-			
79	Reserved	-			
80	Reserved	-			



**NOTE:**

The GC864-QUAD V2 Modules has one DVI ports on the system interface.

**NOTE:**

Reserved pins must not be connected.

**NOTE:**

RTS must be connected to the GND (on the module side) if flow control is not used.

**NOTE:**

If not used, almost all pins must be left disconnected. The only exceptions are the following pins:





Pin	Signal	Function
1	VBATT	Main power supply
2	VBATT	Main power supply
3	VBATT	Main power supply
4	VBATT	Main power supply
5	GND	Ground
6	GND	Ground
7	GND	Ground
46	GND	Ground
25	C103/TXD	Serial data input (TXD) from DTE
26	C104/RXD	Serial data output to DTE
31	C105/RTS	Input for Request to send signal (RTS) from DTE
53	ON/OFF*	Input command for switching power ON or OFF (toggle command).
54	RESET*	Reset input
23	RX_TRACE	RX Data for debug monitor
24	TX_TRACE	TX Data for debug monitor
47	SERVICE	SERVICE connection

## 4.2.2. GC864-QUAD V2 Antenna Connector

The GC864-QUAD V2 module is equipped with a 50 ohm RF connector from Murata, GSC type P/N MM9329-2700B.

The counterpart suitable is Murata MXTK92 Type or MXTK88 Type. Moreover, the GC864-QUAD V2 has the antenna pads on the back side of the PCB. This allows the manual soldering of the coaxial cable directly on the back side of the PCB. However, the soldering is not an advisable solution for a reliable connection of the antenna.



## 5. Hardware Commands

### 5.1. Turning ON the GE/GC864-QUAD V2 and GE864-GPS

To turn ON the GE/GC864-QUAD V2 AND GE864-GPS the pad ON# must be tied low for at least 1 second and then released. Pulse duration less than 1000ms should also start the power on procedure, but this is not guaranteed.

When the power supply voltage is lower than 3.4V the pad ON# must be tied low for at least 4 seconds.

The maximum current that can be drained from the ON# pad is 0.1 mA.  
A simple circuit to do it is:

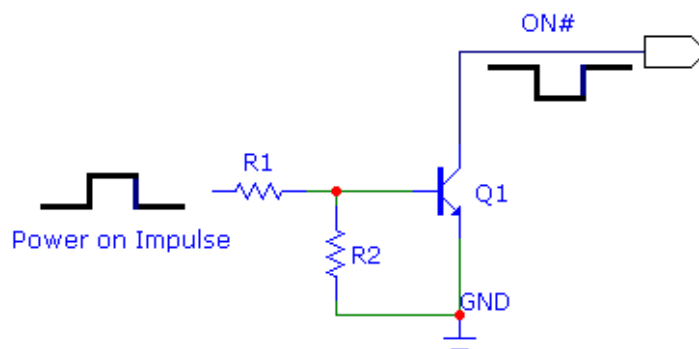

**NOTE:**

Don't use any pull up resistor on the ON# line, it is internally pulled up. Using pull up resistor may bring to latch up problems on the module, power regulator and improper power on/off of the module. The line ON# must be connected only in open collector configuration.



**NOTE:**

In this document all the lines that are inverted, hence have active low signals are labeled with a name that ends with a "#".





**TIP:**

To check if the device has powered on, the hardware line PWRMON should be monitored. After 1000ms the line raised up the device could be considered powered on.



**NOTE:**

When the power supply voltage is lower than 3.4V, to turn ON the module, the pad ON# must be tied low for at least 3 seconds.

For example:

Let us assume you need to drive the ON# pad with a totem pole output from +1.8V up to 5V microcontroller:

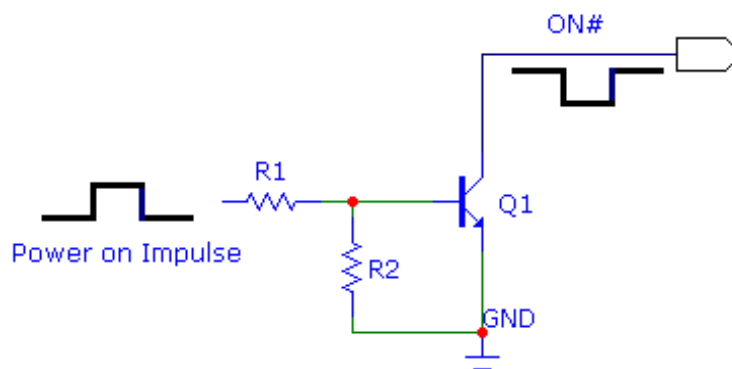

Let us assume you need to drive the ON# pad directly with an ON/OFF button:

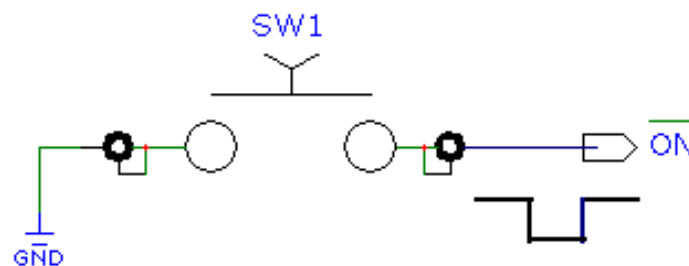

A flow chart showing the proper turn on procedure is displayed below:

flow chart showing the



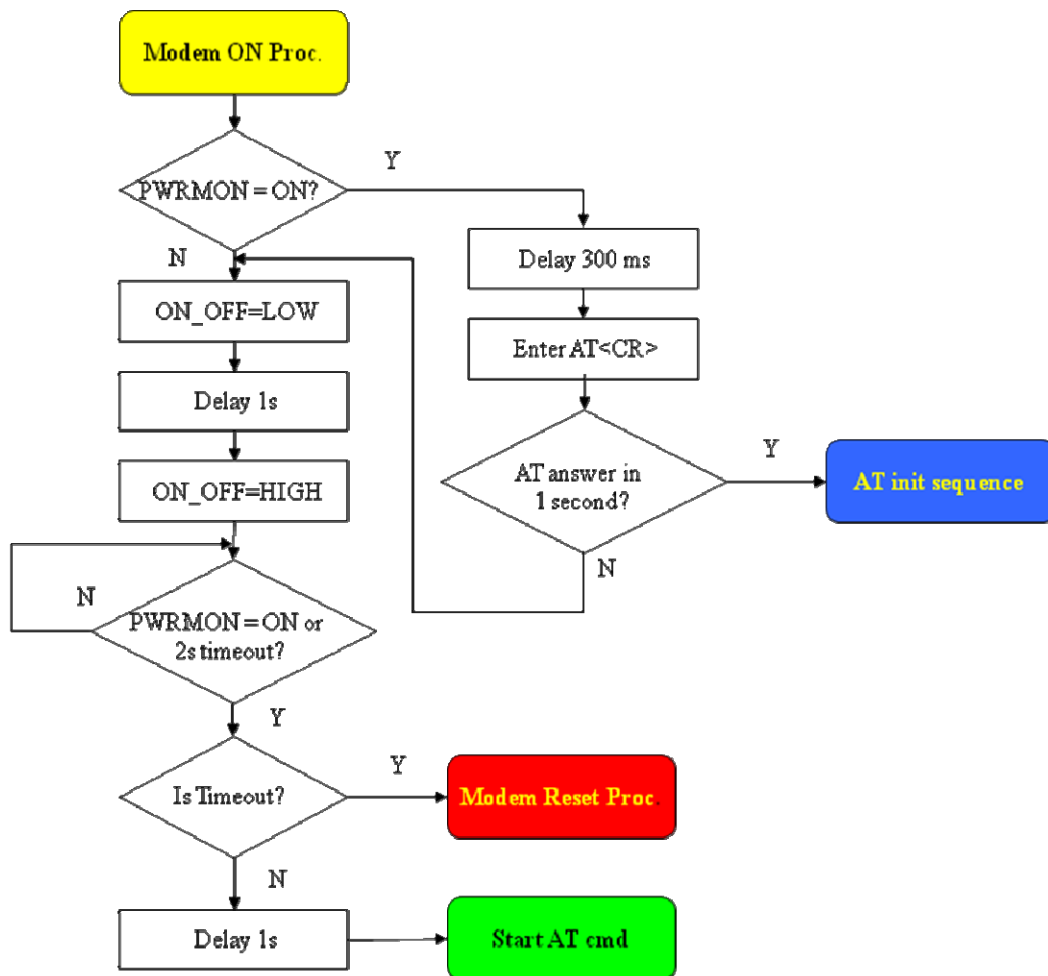

**NOTE:**

In order to avoid a back powering effect it is recommended to avoid having any HIGH logic level signal applied to the digital pins of the module when is powered OFF or during an ON/OFF transition.



A flow chart showing the AT commands managing procedure is displayed below:

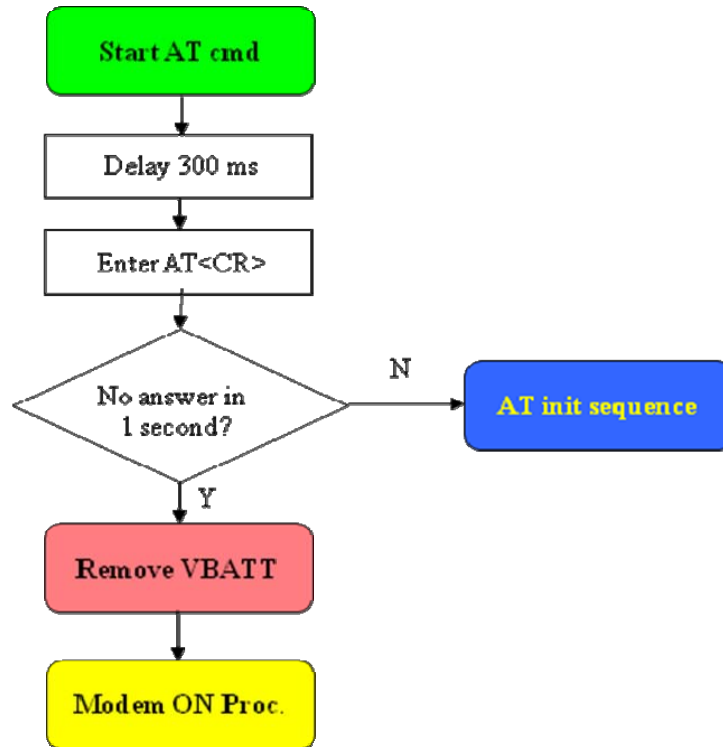

## 5.2. Turning OFF the GE/GC864-QUAD V2 and GE864 GPS

The turning off of the device can be done in two ways:

- via AT command (see Software User Guide AT#SHDN)
- by tying low pin ON#

Either ways, when the device issues a detach request to the network informing that the device will not be reachable any more.

To turn OFF the module the pad ON# must be tied low for at least 2 seconds and then released.



The same circuitry and timing for the power on shall be used.

The device shuts down after the release of the ON# pad.

The following flow chart shows the proper turnoff procedure:

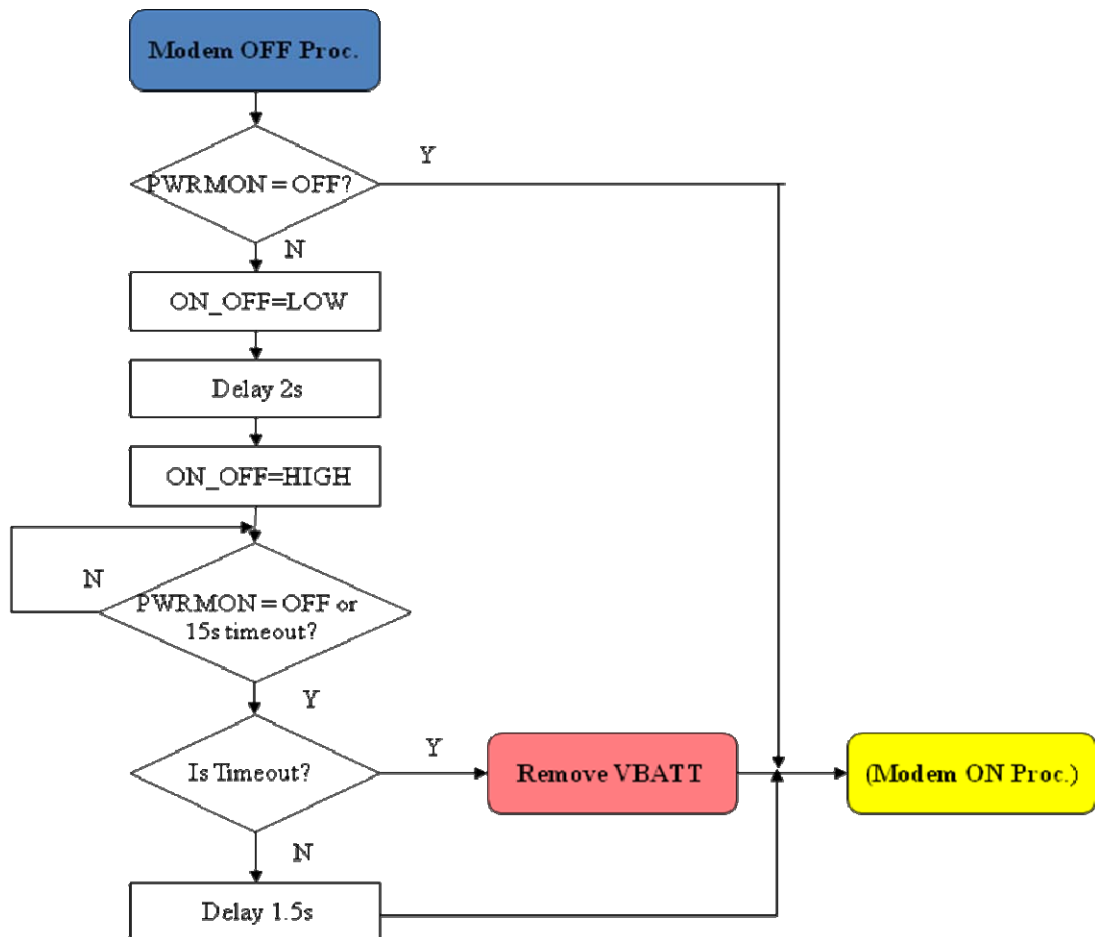

**TIP:**

To check if the device has been powered off, the hardware line PWRMON must be monitored. The device is powered off when PWRMON goes low.





**NOTE:**

In order to avoid a back powering effect it is recommended to avoid having any HIGH logic level signal applied to the digital pins of the module when is powered OFF or during an ON/OFF transition.

### 5.3. Hardware Unconditional Restart



**WARNING:**

The hardware unconditional Restart must not be used during normal operation of the device since it does not detach the device from the network. It shall be kept as an emergency exit procedure to be done in the rare case that the device gets stacked waiting for some network or SIM responses.

To unconditionally restart the module, the pad RESET# must be tied low for at least 200 milliseconds and then released.

The maximum current that can be drained from the RESET# pad is 0.15 mA.

A simple circuit to do it is:

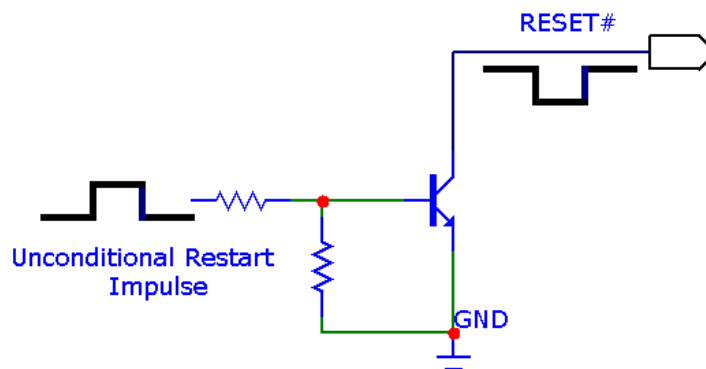

**NOTE:**

Do not use any pull up resistor on the RESET# line or any totem pole digital output. Using pull up resistor may bring to latch up problems on the module power regulator and improper functioning of the module. The line RESET# must be connected only in open collector configuration.





**TIP:**

The unconditional hardware Restart must always be implemented on the boards and must be used by the software as an emergency exit procedure.

The following flow chart shows the proper RESET procedure:

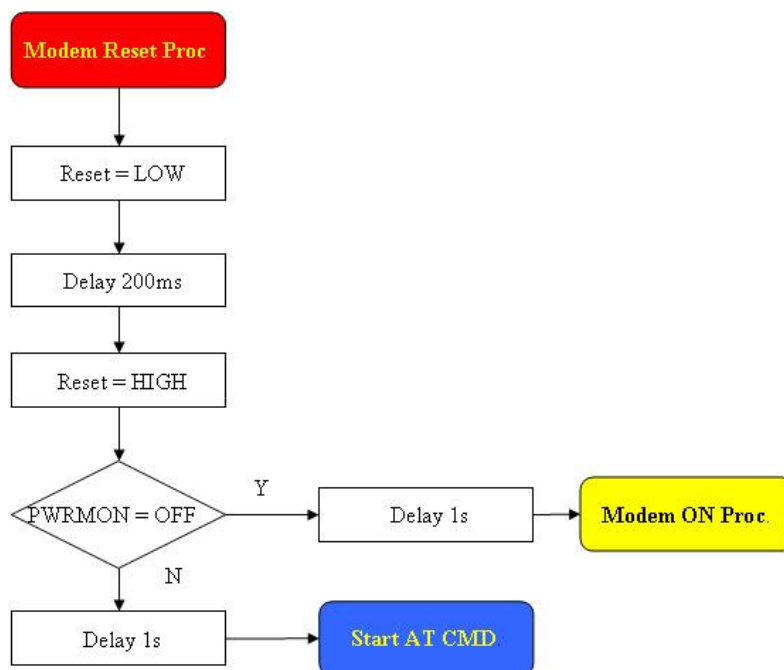

**NOTE:**

In order to avoid a back powering effect it is recommended to avoid having any HIGH logic level signal applied to the digital pins of the module when is powered OFF or during an ON/OFF transition.





For example:

Let us assume you need to drive the RESET# pad with a totem pole output from +1.8V up to 5V microcontroller

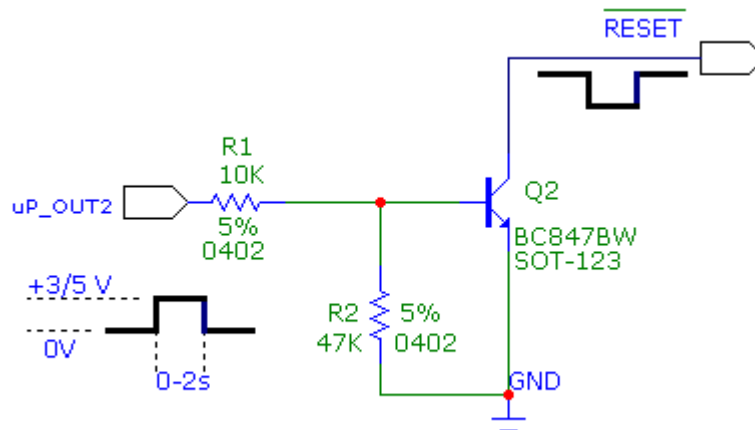

This signal is internally pulled up so the pin can be left floating if not used.

## 5.4. Turning ON/OFF the GPS (only GE864-GPS)

When GPS is not in GSM controlled mode (controlled by GSM) a specific sequence to power-up and shutdown it's needed.

### 5.4.1. GPS Power-up

After you first apply power the GPS part of GE864-GPS goes into a low-power mode status. To switch ON the GPS part is requested a pulse at the input pin GPS\_ON\_OFF. In order to know when the GPS is ready to accept the pulse, the application in the host controller can either:

- Wait for a fixed interval
- Monitor a pulse on GPS\_WAKEUP output
- Assert a pulse on the GPS\_ON\_OFF input every seconds until GPS starts indicating a high on GPS\_WAKEUP output or generation of serial messages.

The GPS starts after asserting a rising edge pulse on GPS\_ON\_OFF input and when high level persists for at least three cycles of RTC clock. Before asserting another pulse to GPS\_ON\_OFF input, the host controller must put it at low state and hold it low for at least three cycles of the RTC clock.

The GPS\_WAKEUP output goes high indicating the GPS is working.



As suggested in chapter 4.1.1 (Pin Out) do not leave the GPS\_ON\_OFF (ball J4) input pin floating. It's suggested to connect it to a pull-down resistor (e.g.: 100k)

## 5.4.2. GPS Shutdown

When GPS is working, a pulse on the GPS\_ON\_OFF input origins the GPS shutdown sequence.

As explained for power-up, a rising edge pulse followed by an high level logic for at least three cycles of RTC clock is recognized as an GPS\_ON\_OFF pulse. Before asserting another pulse to GPS\_ON\_OFF input, the host controller must put it at low state and hold it low for at least three cycles of the RTC clock.

The shutdown sequence may take anywhere from 10ms to 900ms, depending on operation in progress.

Avoid any abrupt, uncontrolled removal of power (VBATT) while GPS is operating. Before removing the supply from the module, perform the shutdown sequence. Performance degradation may be the consequences of any uncontrolled removal of main power.



## 6. Power Supply

The power supply circuitry and board layout are a fundamental part of the product design and they strongly reflect on the product overall performances, hence read carefully the following requirements and guidelines for a proper design.

### 6.1. Power Supply Requirements

Condition	Value
Nominal Supply Voltage	3.80 V
Normal operating Voltage Range	3.40 V - 4.20 V
Extended operating Voltage Range	3.22 V – 4.50 V



**TIP:**

The supply voltage is directly measured between VBATT and GND balls. It must stay within the Wide Supply Voltage tolerant range including any drop voltage and overshoot voltage (during the slot TX, for example).



**NOTE:**

The Operating Voltage Range **MUST** never be exceeded also in power off condition; care must be taken in order to fulfill min/max voltage requirement



**NOTE:**

When the power supply voltage is lower than 3.4V, to turn ON the module, the pad ON# must be tied low for at least 3 seconds



## 6.2. Power Consumption

The table below shows the power consumption of the GSM/GPRS section in different working modes (common for all the modules):

<b>GE\GC864-QUAD V2 and GE864-GPS (GPS OFF)</b>		
<b>Mode</b>	<b>Average (mA)</b>	<b>Mode description</b>
<b>SWITCHED OFF</b>		
Switched Off	<62 uA	Module supplied but Switched Off
<b>IDLE mode</b>		
AT+CFUN=1	16.0	Normal mode: full functionality of the module
AT+CFUN=4	16.0	Disabled TX and RX; module is not registered on the network
AT+CFUN=0 or =5	3.9	Paging Multiframe 2
	2.5	Paging Multiframe 3
	2.4	Paging Multiframe 4
	1.5	Paging Multiframe 9
<b>CSD TX and RX mode</b>		
GSM900 CSD PL5	240	GSM VOICE CALL
DCS1800 CSD PL0	175	
<b>GPRS (class 10) 1TX</b>		
GSM900 PL5	225	GPRS Sending data mode
DCS1800 PL0	160	
<b>GPRS (class 10) 2TX</b>		
GSM900 PL5	420	GPRS Sending data mode
DCS1800 PL0	290	

For the GE864-GPS, the additional current consumption of the GPS section in different operating modes is:

<b>GE864-GPS (GPS ON)</b>		
<b>-Additional current -</b>		
<b>Mode</b>	<b>Average (mA)</b>	<b>Mode description</b>
<b>HIBERNATE</b>	<0.045	only RTC and RAM supplied
<b>Acquisition mode</b>	45	
<b>Tracking mode</b>	37	



The GSM system is made in a way that the RF transmission is not continuous, else it is packed into bursts at a base frequency of about 216 Hz, the relative current peaks can be as high as about 2A. Therefore the power supply has to be designed in order to withstand with these current peaks without big voltage drops; this means that both the electrical design and the board layout must be designed for this current flow.

If the layout of the PCB is not well designed a strong noise floor is generated on the ground and the supply; this will reflect on all the audio paths producing an audible annoying noise at 216 Hz; if the voltage drop during the peak current absorption is too much, then the device may even shutdown as a consequence of the supply voltage drop.



**TIP:**

The electrical design for the Power supply should be made ensuring it will be capable of a peak current output of at least 2A.

## 6.3. General Design Rules

The principal guidelines for the Power Supply Design embrace three different design steps:

- the electrical design
- the thermal design
- the PCB layout.

### 6.3.1. Electrical Design Guidelines

The electrical design of the power supply depends strongly from the power source where this power is drained. We will distinguish them into three categories:

- +5V input (typically PC internal regulator output)
  - +12V input (typically automotive)
  - Battery
- **+5V input Source Power Supply Design Guidelines**
    - The desired output for the power supply is 3.8V, hence there is no big difference between the input source and the desired output. A linear regulator can be used. A switching power supply will not be suited because of the low drop out requirements.
    - When using a linear regulator, a proper heat sink shall be provided in order to dissipate the power generated.
    - A Bypass low ESR capacitor of adequate capacity must be provided in order to cut the current absorption peaks close to the module, a 100µF tantalum capacitor is usually suited.
    - Make sure the low ESR capacitor on the power supply output (usually a tantalum one) is rated at least 10V.
    - A protection diode can be inserted close to the power input, in order to save the module from power polarity inversion.



An example of linear regulator with 5V input is:

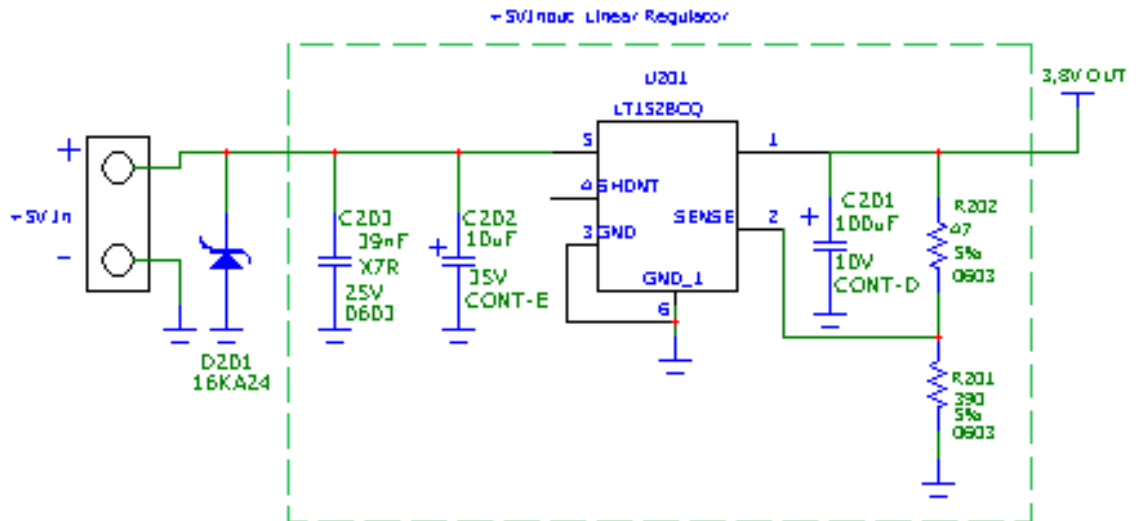

- **+12V input Source Power Supply Design Guidelines**

- The desired output for the power supply is 3.8V, hence, due to the big difference between the input source and the desired output, a linear regulator is not suited and shall not be used. A switching power supply will be preferable because of its better efficiency especially with the 2A peak current load represented by the module.
- When using a switching regulator, a 500kHz (or more) switching frequency regulator is preferable, because of its smaller inductor size and its faster transient response. This allows the regulator to respond quickly to the current peaks absorption.
- In any case the frequency and switching design selection is related to the application to be developed, due to the fact that the switching frequency could also generate EMC interferences.
- As far as car PB battery, the input voltage can rise up to 15.8V. This must be kept in mind when choosing components: all components in the power supply must withstand this voltage.
- A Bypass low ESR capacitor of adequate capacity must be provided, in order to cut the current absorption peaks. A 100µF tantalum capacitor is typically used.
- Make sure the low ESR capacitor on the power supply output (usually a tantalum one) is rated at least 10V.
- As far as car applications, a spike protection diode must be inserted close to the power input, in order to clean the supply from spikes.



## GE/GC864-QUAD V2 and GE864-GPS Hardware User Guide

1vv0300915 Rev.2 – 2011-06-15

- A protection diode can be inserted close to the power input, in order to save the module from power polarity inversion. This can be the same diode used for spike protection.

An example of switching regulator with 12V input is in the schematic below (split in 2 parts):

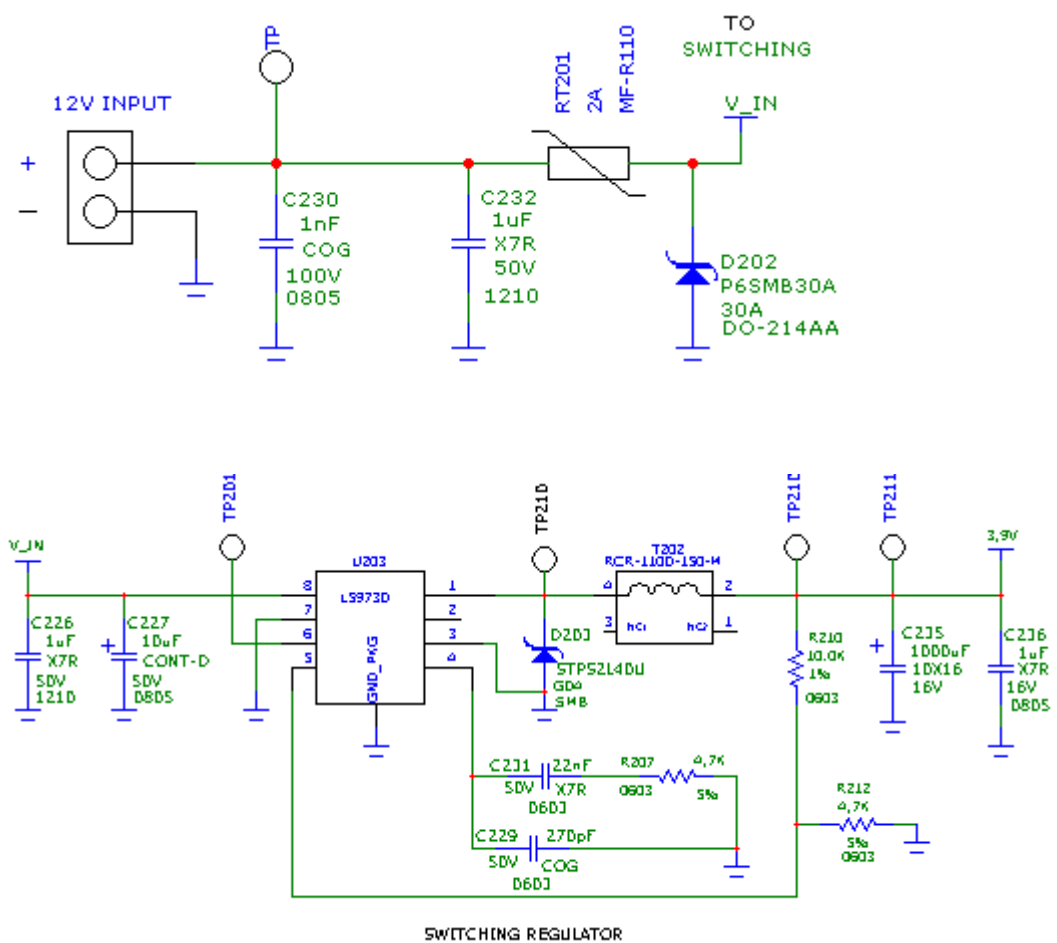

### 6.3.2. Battery Source Power Supply Design Guidelines

- The desired nominal output for the power supply is 3.8V and the maximum voltage allowed is 4.2V, hence a single 3.7V Li-Ion cell battery type is suited for supplying the power to the Telit GE/GC864-QUAD V2 AND GE864-GPSmodules.



The three cells Ni/Cd or Ni/MH 3,6 V Nom. battery types or 4V PB types **MUST NOT BE USED DIRECTLY** since their maximum voltage can rise over the absolute maximum voltage for the module and damage it.



**WARNING:**

DON'T USE any Ni-Cd, Ni-MH, and Pb battery types directly connected with GE/GC864-QUAD V2 and GE864-GPS. Their use can lead to overvoltage on the module and damage it. USE ONLY Li-Ion battery types.

- A Bypass low ESR capacitor of adequate capacity must be provided in order to cut the current absorption peaks, a 100µF tantalum capacitor is usually suited.
- Make sure the low ESR capacitor (usually a tantalum one) is rated at least 10V.
- A protection diode should be inserted close to the power input, in order to save the module from power polarity inversion. Otherwise the battery connector should be done in a way to avoid polarity inversions when connecting the battery.
- The battery capacity must be at least 500mAh in order to withstand the current peaks of 2A; the suggested capacity is from 500mAh to 1000mAh.

### 6.3.3. Thermal Design Guidelines

The thermal design for the power supply heat sink must be done with the following specifications:

- Average current consumption during transmission @PWR level max: 500mA
- Average current consumption during transmission @ PWR level min: 100mA
- Average current during Power Saving (CFUN=5): from 1.5 to 3.9mA
- Average current during idle (Power Saving disabled): 16mA



**NOTE:**

The average consumption during transmissions depends on the power level at which the device is requested to transmit by the network. The average current consumption hence varies significantly.

Considering the very low current during idle, especially if Power Saving function is enabled, it is possible to consider from the thermal point of view that the device absorbs current significantly only during calls.

If we assume that the device stays into transmission for short periods of time (let us say few minutes) and then remains for a quite long time in idle (let us say one hour), then the power supply has always the time to cool down between the calls, and the heat sink could be smaller than the calculated one for 500mA maximum RMS current, or even could be the simple chip package (no heat sink).





Moreover, in the average network conditions, the device is requested to transmit at a lower power level than the maximum, hence the current consumption will be less than 500mA, usually around 150mA.

For these reasons the thermal design is rarely a concern and the simple ground plane where the power supply chip is placed grants a good thermal condition to avoid overheating as well. As far as the heat generated by GC/GE864-QUAD V2 and GE864-GPS , you can consider it to be during transmissions of 1W max during CSD/VOICE calls and 2W max during class10 GPRS upload.

This generated heat will be mostly conducted to the ground plane under GC/GE864-QUAD V2 AND GE864-GPS ; you must ensure that your application can dissipate it.

#### 6.3.4. Power Supply PCB Layout Guidelines

As seen on the electrical design guidelines the power supply shall have a low ESR capacitor on the output to cut the current peaks and a protection diode on the input to protect the supply from spikes and polarity inversion. The placement of these components is crucial for the correct working of the circuitry. A misplaced component can be useless or can even decrease the power supply performances.

- The Bypass low ESR capacitor must be placed close to the Telit GE/GC864-QUAD V2 and GE864-GPS power input pads or in the case the power supply is a switching type it can be placed close to the inductor to cut the ripple provided the PCB trace from the capacitor to the GE/GC864-QUAD V2 and GE864-GPS wide enough to ensure a dropleless connection even during the 2A current peaks.
- The protection diode must be placed close to the input connector where the power source is drained.
- The PCB traces from the input connector to the power regulator IC must be wide enough to ensure no voltage drops occur when the 2A current peaks are absorbed. Note that this is not made in order to save power loss but especially to avoid the voltage drops on the power line at the current peaks frequency of 216 Hz that will reflect on all the components connected to that supply, introducing the noise floor at the burst base frequency. For this reason while a voltage drop of 300-400 mV may be acceptable from the power loss point of view, the same voltage drop may not be acceptable from the noise point of view. If your application does not have audio interface but only uses the data feature of the Telit GE/GC864-QUAD V2 and GE864-GPS then this noise is not so disturbing and power supply layout design can be more forgiving.
- The PCB traces to the GE/GC864-QUAD V2 and GE864-GPS and the Bypass capacitor must be wide enough to ensure no significant voltage drops occur when the 2A current peaks are absorbed. This is for the same reason as previous point. Try to keep this trace as short as possible.
- The PCB traces connecting the Switching output to the inductor and the switching diode must be kept as short as possible by placing the inductor and the diode very close to the power switching IC (only for switching power supply). This is done in order to reduce the radiated field (noise) at the switching frequency (100-500 kHz usually).
- The use of a good common ground plane is suggested.



- The placement of the power supply on the board must be done in such a way to guarantee that the high current return paths in the ground plane are not overlapped to any noise sensitive circuitry as the microphone amplifier/buffer or earphone amplifier.
- The power supply input cables must be kept separate from noise sensitive lines such as microphone/earphone cables.

### 6.3.5. Parameters for ATEX Applications

In order to integrate the Telit's modules into an ATEX application, the appropriate reference standard IEC EN xx and integrations shall be followed.

Below are listed parameters and useful information to integrate the module in your application:

#### GE864-QUAD V2

- Total capacity: 27.45 uF
- Total inductance: 55.20 nH
- No voltage upper than supply voltage is present in the module.
- No step-up converters are present in the module.

#### GC864-QUAD V2

- Total capacity: 27.45 uF
- Total inductance: 55.20 nH
- No voltage upper than supply voltage is present in the module.
- No step-up converters are present in the module.

#### GE864-GPS

- Total capacity: 33.26 uF
- Total inductance: 233 nH
- No voltage upper than supply voltage is present in the module.
- No step-up converters are present in the module.



## 7. Antenna

The antenna(s) connection and board layout design are the most important part in the full product design and they strongly reflect on the product overall performances, hence read carefully and follow the requirements and the guidelines for a proper design.

### 7.1. GSM Antenna (GE864-QUAD V2/GPS and GC864-QUAD V2)

#### 7.1.1. GSM Antenna Requirements

As suggested on the Product Description the antenna for Telit GE/GC864-QUAD V2 and GE864-GPS devices shall fulfill the following requirements:

ANTENNA REQUIREMENTS	
<b>Frequency range</b>	Depending by frequency band(s) provided by the network operator, the customer shall use the most suitable antenna for that/those band(s)
<b>Bandwidth</b>	70 MHz in GSM850, 80 MHz in GSM900, 170 MHz in DCS & 140 MHz PCS band
<b>Gain</b>	Gain < 1,4dBi in GSM 850 & 900 and < 3,0dBi DCS & PCS
<b>Impedance</b>	50 ohm
<b>Input power</b>	> 2 W peak power
<b>VSWR absolute max</b>	<= 10:1 (limit to avoid permanent damage)
<b>VSWR recommended</b>	<= 2:1 (limit to fulfill all regulatory requirements)

Furthermore if the devices are developed for the US market and/or Canada market, they shall comply to the FCC and/or IC approval requirements:

Those devices are to be used only for mobile and fixed application. The antenna(s) used for this transmitter must be installed to provide a separation distance of at least 20 cm from all persons and must not be co-located or operating in conjunction with any other antenna or transmitter. End-Users must be provided with transmitter operation conditions for satisfying RF exposure compliance. OEM integrators must ensure that the end user has no manual instructions to remove or install the GE/GC864-QUAD V2 AND GE864-GPS modules. Antennas used for those OEM modules must not exceed 3dBi gain for mobile and fixed operating configurations.



### 7.1.2. GE864-QUAD V2/GPS GSM Antenna – PCB line Guidelines

When using the Telit GE864-QUAD V2 module, since there's no antenna connector on the module, the antenna must be connected to the GE864-QUAD V2 through the PCB with the antenna pad.

In the case that the antenna is not directly developed on the same PCB, hence directly connected at the antenna pad of the GE864-QUAD V2, then a PCB line is needed in order to connect with it or with its connector.

This line of transmission shall fulfill the following requirements:

ANTENNA LINE ON PCB REQUIREMENTS	
<b>Impedance</b>	50 ohm
<b>Max Attenuation</b>	0,3 dB
<b>No coupling with other signals allowed</b>	
<b>Cold End (Ground Plane) of antenna shall be equipotential to the GE864-QUAD V2 ground pins</b>	

This transmission line should be designed according to the following guidelines:

- Ensure that the antenna line impedance is 50 ohm;
- Keep the antenna line on the PCB as short as possible, since the antenna line loss shall be less than 0,3 dB;
- Antenna line must have uniform characteristics, constant cross section, avoid meanders and abrupt curves;
- Keep, if possible, one layer of the PCB used only for the Ground plane;
- Surround (on the sides, over and under) the antenna line on PCB with Ground, avoid having other signal tracks facing directly the antenna line track;
- The ground around the antenna line on PCB has to be strictly connected to the Ground Plane by placing vias once per 2mm at least;
- Place EM noisy devices as far as possible from GE864-QUAD V2 antenna line;
- Keep the antenna line far away from the GE864-QUAD V2 power supply lines;
- If you have EM noisy devices around the PCB hosting the GE864-QUAD V2, such as fast switching ICs, take care of the shielding of the antenna line by burying it inside the layers of PCB and surround it with Ground planes, or shield it with a metal frame cover.
- If you don't have EM noisy devices around the PCB of GE864-QUAD V2, by using a strip-line on the superficial copper layer for the antenna line, the line attenuation will be lower than a buried one;



### 7.1.3. GSM Antenna – Installation Guidelines

Install the antenna in a place covered by the GSM signal.

- The Antenna must be installed to provide a separation distance of at least 20 cm from all persons and must not be co-located or operating in conjunction with any other antenna or transmitter;
- Antenna shall not be installed inside metal cases
- Antenna shall be installed also according Antenna manufacturer instructions.

## 7.2. GPS Antenna (GE864-GPS only)

### 7.2.1. GPS Antenna Requirements

The GE864-GPS module is provided with an internal LNA amplifier with two selectable gain level. By default the GE864-GPS is configured in high gain mode (18dB with 2dB of noise figure).

If the external antenna is connected to the DUT with a long coax cable, the use of an external LNA close to the antenna feed point is recommended. In this case the module must be configured in low gain mode (8dB with 10dB of noise figure) through a specific AT command (refer to AT\$GPSAT on AT Commands Reference Guide, 80000ST10025a). The module provides a digital output signal (GPS\_LNA\_EN) used for RF power control that can be used to enable the external LNA.

---

NOTE: when the internal LNA is in high gain mode, the GPS\_LNA\_EN output is tied low (external LNA unused).



NOTE: The typical external gain range is 20 dB (when in low gain mode, not recommended in high gain mode)

NOTE: The absolute maximum rating for GPS RF input power is 10 dBm  
Combined GPS Antenna

---

The use of combined GPS antennas is NOT recommended; this solution could generate an extremely poor GPS reception and also the combination antenna requires additional diplexer and adds a loss in the RF route.

### 7.2.2. Linear and Patch GPS Antenna

Using this type of antenna introduces at least 3 dB of loss if compared to a circularly polarized (CP) antenna. Having a spherical gain response instead of a hemispherical gain response could aggravate the multipath behaviour & create poor position accuracy.

### 7.2.3. GPS Antenna - PCB Line Guidelines

- Ensure that the antenna line impedance is 50Ω.



- Keep the antenna line on the PCB as short as possible to reduce the loss.
- Antenna line must have uniform characteristics, constant cross section, avoid meanders and abrupt curves.
- Keep one layer of the PCB used only for the Ground plane, if possible.
- Surround (on the sides, over and under) the antenna line on PCB with Ground, avoid having other signal tracks facing directly the antenna line of track.
- The ground around the antenna line on PCB has to be strictly connected to the Ground Plane by placing vias once per 2mm at least.
- Place EM noisy devices as far as possible from GE864-GPS antenna line.
- Keep the antenna line far away from the GE864-GPS power supply lines.
- Keep the antenna line far away from the GE864-GPS GSM RF lines.
- If you have EM noisy devices around the PCB hosting the GE864-GPS, such as fast switching ICs, take care of the shielding of the antenna line by burying it inside the layers of PCB and surround it with Ground planes, or shield it with a metal frame cover.
- If you do not have EM noisy devices around the PCB of GE864-GPS, use a strip-line on the superficial copper layer for the antenna line. The line attenuation will be lower than a buried one.

#### 7.2.4. GPS Antenna - Installation Guidelines

- The GE864-GPS due to its characteristics of sensitivity is capable to perform a Fix inside the buildings. (In any case the sensitivity could be affected by the building characteristics i.e. shielding).
- The Antenna must not be co-located or operating in conjunction with any other antenna or transmitter.
- Antenna must not be installed inside metal cases.
- Antenna must be installed also according Antenna manufacturer instructions.



## 8. Logic Level Specifications

Where not specifically stated, all the interface circuits work at 2.8V CMOS logic levels. The following table shows the logic level specifications used in the Telit GE/GC864-QUAD V2 AND GE864-GPS interface circuits:

### Absolute Maximum Ratings – Not Functional

Parameter	Min	Max
Input level on any digital pin when on	-0.3V	+3.1V
Input voltage on analog pins when on	-0.3V	+3.0 V

### Operating Range – Interface Levels (2.8V CMOS)

Level			GPS signals	
	Min	Max	Min	Max
Input high level	2.1V	3.1V	1.82V	2.8V
Input low level	0V	0.5V	0V	0.98V
Output high level	2.2V	3.0V	2.4V	
Output low level	0V	0.35V		0.4V

For 1,8V signals:

### Operating Range – Interface Levels (1.8V CMOS)

Level			GPS signals	
	Min	Max	Min	Max
Input high level	1.6V	2.2V	1.26V	3.1V
Input low level	0V	0.4V		0.45V
Output high level	1,65V	2.2V	1.2V	
Output low level	0V	0.35V		0.45V

### Current characteristics

Level	Typical
Output Current	1mA
Input Current	1uA



## 8.1. Reset Signal

Signal	Function	I/O	Ball/Pin Number
RESET	Reset	I	A2 on GE864-QUAD V2/GPS 54 on GC864-QUAD V2

RESET is used to reset the GE/GC864-QUAD V2 and GE864-GPS modules. Whenever this signal is pulled low, the GE/GC864-QUAD V2 and GE864-GPS are reset. When the device is reset it stops any operation. After the release of the reset GE/GC864-QUAD V2 and GE864-GPS are unconditionally shut down, without doing any detach operation from the network where it is registered. This behavior is not a proper shut down because any GSM device is requested to issue a detach request on turn off. For this reason the Reset signal must not be used to normally shutting down the device, but only as an emergency exit in the rare case the device remains stuck waiting for some network response.

The RESET is internally controlled on start-up to achieve always a proper power-on reset sequence, so there is no need to control this pin on start-up. It may only be used to reset a device already on that is not responding to any command.



### NOTE:

Do not use this signal to power off GC/GE864-QUAD V2 and GE864-GPS . Use the ON/OFF signal to perform this function or the AT#SHDN command.

### Reset Signal Operating Levels:

Signal	Min	Max
RESET Input high	2.0V*	2.2V
RESET Input low	0V	0.2V

\* this signal is internally pulled up so the pin can be left floating if not used.

If unused, this signal may be left unconnected. If used, then it **must always be connected with an open collector transistor**, to permit to the internal circuitry the power on reset and under voltage lockout functions.





## 9. Serial Ports

The serial port on the Telit GE864/GC864-QUAD V2 and GE864-GPS is the core of the interface between the module and OEM hardware.

2 serial ports are available on the GE864-QUAD/GC864-QUAD V2 modules:

- MODEM SERIAL PORT (Main, ASC0)
- MODEM SERIAL PORT 2 (Auxiliary, ASC1)

While another serial port is available on the GE864-QUAD V2/GPS module:

- GPS SERIAL PORT (NMEA)

### 9.1. MODEM SERIAL PORT

Several configurations can be designed for the serial port on the OEM hardware, but the most common are:

- RS232 PC com port
- microcontroller UART @ 2.8V – 3V (Universal Asynchronous Receive Transmit)
- microcontroller UART@ 5V or other voltages different from 2.8V
- Depending from the type of serial port on the OEM hardware a level translator circuit may be needed to make the system work. The only configuration that does not need a level translation is the 2.8V UART.

The serial port on the GE/GC864-QUAD V2 and GE864-GPS a +2.8V UART with all the 7 RS232 signals. It differs from the PC-RS232 in the signal polarity (RS232 is reversed) and levels. The levels for the GE864-QUAD V2 UART are the CMOS levels:

#### Absolute Maximum Ratings –Not Functional

Parameter	Min	Max
Input level on any digital pad when on	-0.3V	+3.1V
Input voltage on analog pads when on	-0.3V	+3.0 V

#### Operating Range – Interface levels (2.8V CMOS)

Level			GPS signals	
	Min	Max	Min	Max
Input high level	2.1V	3.1V	1.82V	2.8V
Input low level	0V	0.5V	0V	0.98V
Output high level	2.2V	3.0V	2.4V	
Output low level	0V	0.35V		0.4V



The table below shows the signals of the GE/GC864-QUAD V2 AND GE864-GPSserial port:

RS232 Pin Number	Signal	GE864-QUAD V2 Pad Number	GC864-QUAD V2 Pad Number	Name	Usage
1	DCD – dcd_uart	D9	32	Data Carrier Detect	Output from the GE864-QUAD V2 that indicates the carrier presence
2	RXD – tx_uart	H8	26	Transmit line *see Note	Output transmit line of GE864-QUAD V2 UART
3	TXD – rx_uart	E7	25	Receive line *see Note	Input receive of the GE864-QUAD V2 UART
4	DTR – dtr_uart	B7	29	Data Terminal Ready	Input to the GE864-QUAD V2 that controls the DTE READY condition
5	GND	A1,F1, H1 L1, H2, L2, J3, K3....	5,6,7	Ground	ground
6	DSR – dsr_uart	E11	27	Data Set Ready	Output from the GE864-QUAD V2 that indicates the module is ready
7	RTS – rts_uart	F7	31	Request to Send	Input to the GE864-QUAD V2 that controls the Hardware flow control
8	CTS – cts_uart	F6	28	Clear to Send	Output from the GE864-QUAD V2 that controls the Hardware flow control
9	RI – ri_uart	B6	30	Ring Indicator	Output from the GE864-QUAD V2 that indicates the incoming call condition



**NOTE:**

According to V.24, RX/TX signal names are referred to the application side, therefore on the GE/GC864-QUAD V2 AND GE864-GPSside these signal are on the opposite direction: TXD on the application side will be connected to the receive line (here named TXD/RX\_uart ) of the GE/GC864-QUAD V2 AND GE864-GPSserial port and viceversa for RX



**TIP:**

For a minimum implementation, only the TXD and RXD lines can be connected, the other lines can be left open provided a software flow control is implemented.



**NOTE:**

In order to avoid a back powering effect it is recommended to avoid having any HIGH logic level signal applied to the digital pins of the module when is powered OFF or during an ON/OFF transition.



## 9.2. GE864-GPS Secondary Ports

### 9.2.1. Modem Serial Port 2 (GPS Control)

This port is the only communication interface with the GPS part. It is available on the following pins:

BALL	NAME	DESCRIPTION	TYPE
D11	TX_AUX	TX Data for GPS control	CMOS 2.8V
F10	RX_AUX	RX Data for GPS control	CMOS 2.8V

Please note that in order for GPS to be controlled by the GSM section, the GPS UART and some GPS control signals **have to be connected externally** to the GSM section according to the following table (see also chapter 12):

BALL	NAME		NAME	BALL
D11	TX_AUX	↔	GPS_RX	E10
F10	RX_AUX	↔	GPS_TX	F8
B3	GPIO4		GPS_ON_OFF	J4
C1	GPIO1		GPS_WAKE_UP	G2

### 9.2.2. GPS Serial Port (NMEA)

This port is carrying out the GPS navigation data in NMEA 0183 format. The default configuration is 4800 bps, 8, n, 1

It is available on the following pins:

BALL	NAME	DESCRIPTION	TYPE
F8	GPS_TX	GPS TX Data (NMEA)	CMOS 2.8V (GPS)
E10	GPS_RX	GPS RX Data (NMEA)	CMOS 2.8V (GPS)

GPS RX Lines and TX lines may need a dual supply isolation buffer like an FXLP34 to avoid CMOS high states while in POWER SAVING.

## 9.3. RS232 Level Translation

In order to interface the Telit GE/GC864-QUAD V2 AND GE864-GPS with a PC com port or a RS232 (EIA/TIA-232) application a level translator is required. This level translator must

- invert the electrical signal in both directions
- change the level from 0/+3V to +15/-15V



Actually, the RS232 UART 16450, 16550, 16650 & 16750 chipsets accept signals with lower levels on the RS232 side (EIA/TIA-562), allowing for a lower voltage-multiplying ratio on the level translator. Note that the negative signal voltage must be less than 0V and hence some sort of level translation is always required.

The simplest way to translate the levels and invert the signal is by using a single chip level translator. There are a multitude of them, differing in the number of driver and receiver and in the levels (be sure to get a true RS232 level translator not a RS485 or other standards).

By convention the driver is the level translator from the 0/+3V UART level to the RS232 level, while the receiver is the translator from RS232 level to 0/+3V UART.

In order to translate the whole set of control lines of the UART you will need:

- 5 driver
- 3 receiver



---

**NOTE:**

The digital input lines working at 2.8V CMOS have an absolute maximum input voltage of 3.0V; therefore the level translator IC shall not be powered by the +3.8V supply of the module. Instead, it must be powered from a +2.7V / +2.9V (dedicated) power supply.

This is because in this way the level translator IC outputs on the module side (i.e. GE/GC 864 inputs) will work at +3.8V interface levels, damaging the module inputs.

---



---

**NOTE:**

In order to be able to do in circuit reprogramming of the GE/GC 864 firmware, the serial port on the Telit GE/GC 864 shall be available for translation into RS232 and either it's controlling device shall be placed into tristate, disconnected or as a gateway for the serial data when module reprogramming occurs.

Only RXD, TXD, GND and the On/off module turn on pad are required to the reprogramming of the module, the other lines are unused.

All applicator shall include in their design such a way of reprogramming the GE/GC 864.

---



**GE/GC864-QUAD V2 and GE864-GPS Hardware User Guide**  
1vv0300915 Rev.2 – 2011-06-15

An example of level translation circuitry of this kind is:

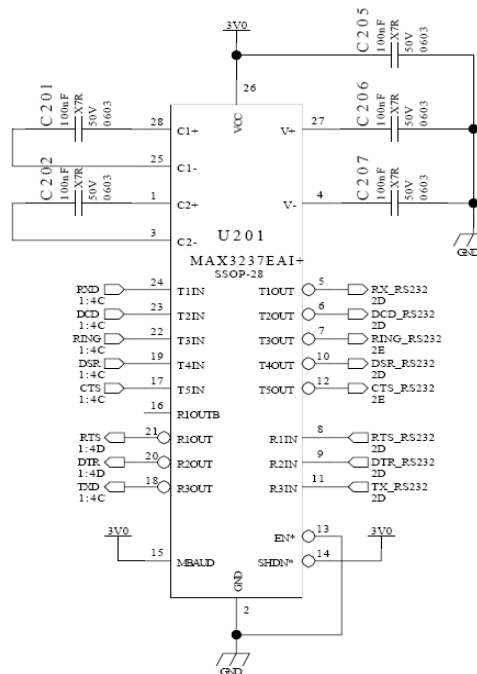

RS232 LEVEL TRSANSULATOR

The RS232 serial port lines are usually connected to a DB9 connector with the following layout:

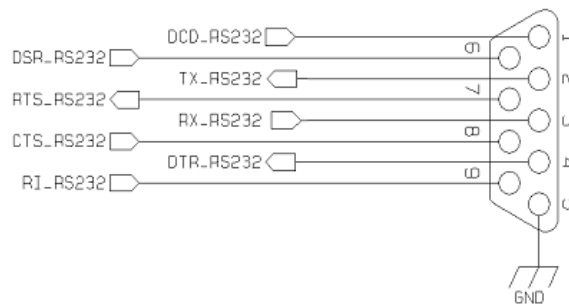

## 9.4. 5V UART Level Translation

If the OEM application uses a microcontroller with a serial port (UART) that works at a voltage different from 2.8 – 3V, then a circuitry has to be provided to adapt the different levels of the two set of signals. As for the RS232 translation there are a multitude of single chip translators. For example a possible translator circuit for a 5V TRANSMITTER/RECEIVER can be:

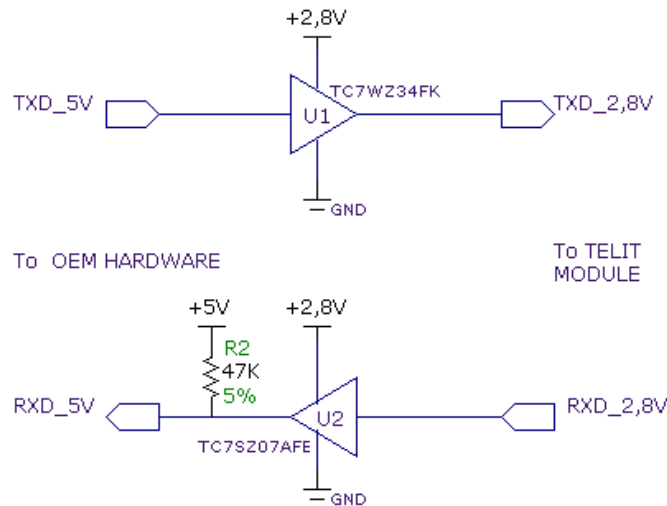

### TIP:

Note that the TC7SZ07AE has open drain output; therefore the resistor R2 is mandatory.



### NOTE:

The UART input line TXD (rx\_uart) of the GE/GC864-QUAD V2 and GE864-GPS NOT internally pulled up with a resistor, so there may be the need to place an external 47KΩ pull-up resistor, either the DTR (dtr\_uart) and RTS (rts\_uart) input lines are not pulled up internally, so an external pull-up resistor of 47KΩ may be required.



Care must be taken to avoid latch-up on the GE/GC864-QUAD V2 and GE864-GPS and the use of this output line to power electronic devices shall be avoided, especially for devices that generate spikes and noise such as switching level translators, micro controllers, failure in any of these condition can severely compromise the GE/GC864-QUAD V2 and GE864-GPS functionality.



### NOTE:

In case of reprogramming of the module has to be considered the use of the RESET line to start correctly the activity.

The preferable configuration is having an external supply for the buffer level translator.



## 10. Audio Section Overview

The first Baseband chip was developed for the cellular phones, which needed two separated amplifiers both in RX and in TX section.

A couple of amplifiers had to be used with internal audio transducers while the other couple of amplifiers had to be used with external audio transducers.

To distinguish the schematic signals and the Software identifiers, two different definitions were introduced, with the following meaning:

- internal audio transducers → **HS/MT** (from **HandSet** or **MicroTelephone**)
- external audio transducers → **HF** (from **HandsFree**)

Actually the acronyms have not the original importance.

In other words this distinction is not necessary, being the performances between the two blocks like the same.

Only if the customer needs higher output power to drive the speaker, he needs to adopt the Aduio2 Section (**HF**). Otherwise the choice could be done in order to overcome the PCB design difficulties.

For these reasons we have not changed the **HS** and **HF** acronyms, keeping them in the Software and on the schematics.

The Base Band Chip of the GE864-QUAD V2 Telit Modules maintains the same architecture. For more information and suggestions refer to Telit document:

- Audio settings application note , 80000NT10007a

### 10.1. Selection mode

Only one block can be active at a time, and the activation of the requested audio path is done via hardware, by **AXE** line, or via software ,by **AT#CAP** command .

Moreover the **Sidetone** functionality could be implemented by the amplifier fitted between the transmit path and the receive path, enabled at request in both modes.



### GE/GC864-QUAD V2 and GE864-GPS Hardware User Guide

1vv0300915 Rev.2 – 2011-06-15

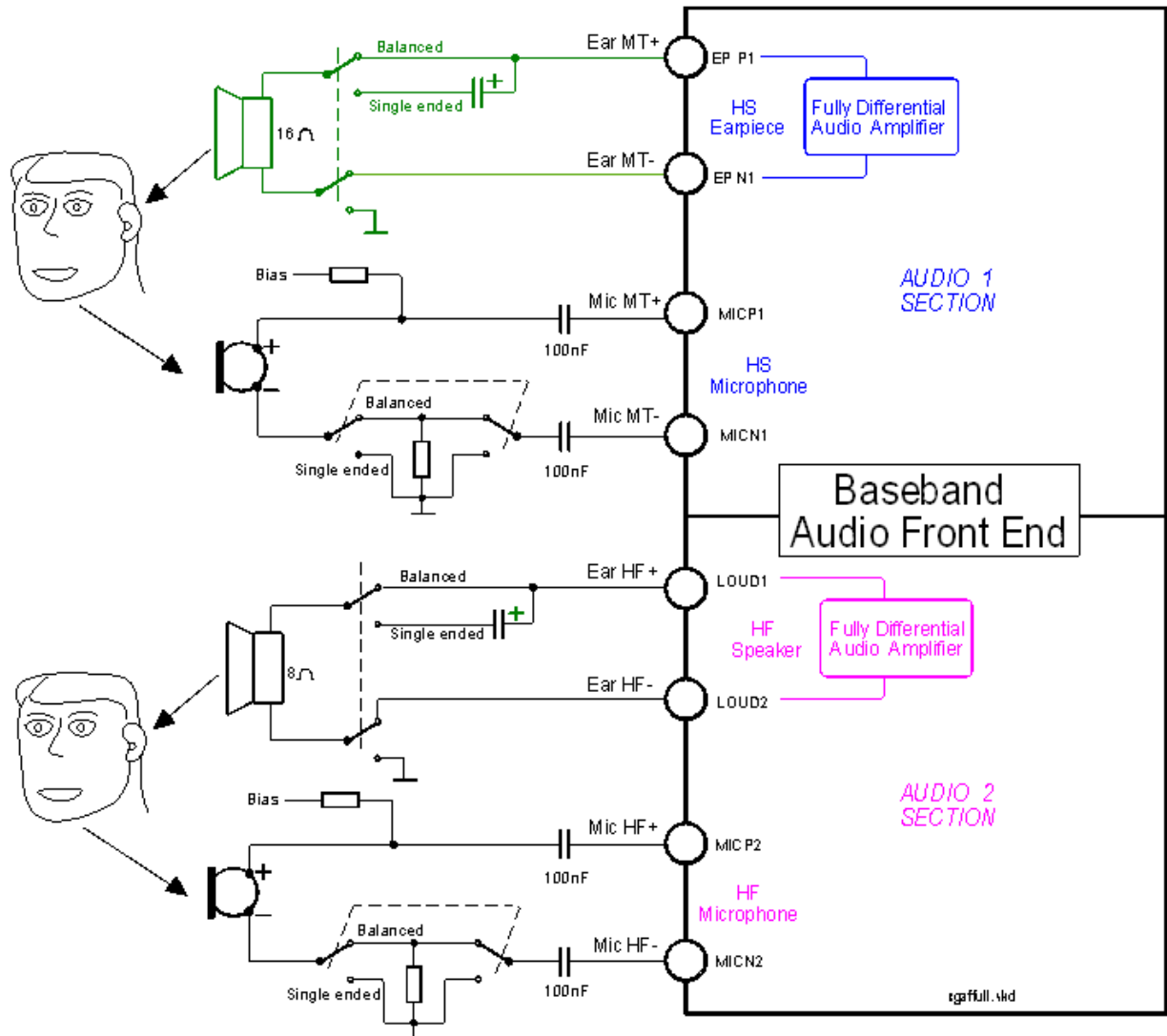

GE864-QUAD V2 Audio Front End Block Diagram





## 10.2. Electrical Characteristics



**TIP:** Being the microphone circuitry the more noise sensitive, its design and layout must be done with particular care. Both microphone paths are balanced and the OEM circuitry must be balanced designed to reduce the common mode noise typically generated on the ground plane. However the customer can use the unbalanced circuitry for its particular application.

### 10.2.1. Input Lines Characteristics

"MIC_MT" and "MIC_HF" differential microphone paths	
Line Coupling	AC*
Line Type	Balanced
Differential input voltage	$\leq 1,03V_{pp}$ @ Mic $G=0dB$
Gain steps	7
Gain increment	6dB per step
Coupling capacitor	$\geq 100nF$
Differential input resistance	50K $\Omega$
Input capacitance	$\leq 10pF$



(\*) **WARNING :** AC means that the signals from the microphone have to be connected to input lines of the module through capacitors which value has to be  $\geq 100nF$ . Not respecting this constraint, the input stages will be damaged.



**WARNING:** when particular OEM application needs a *Single Ended Input* configuration, it is forbidden connecting the unused input directly to Ground, but only through a 100nF capacitor. Don't forget that the useful input signal will be halved in *Single Ended Input* configuration.



## 10.2.2. Output Lines Characteristics



### TIP:

We suggest driving the load differentially from both output drivers, thus the output swing will double and the need for the output coupling capacitor avoided. However if particular OEM application needs also a *Single Ended circuitry* can be implemented, but the output power will be reduced four times.

The OEM circuitry shall be designed to reduce the common mode noise typically generated on the ground plane and to get the maximum power output from the device (low resistance tracks).



### WARNING:

The loads are directly connected to the amplifier outputs when in *Differential* configuration, through a capacitor when in *Single Ended* configuration. Using a *Single Ended configuration*, the unused output line must be left open. Not respecting this constraint, the output stage will be damaged.



### TIP :

Remember that there are slightly different electrical performances between the two internal audio amplifiers:

- the “*Ear\_MT*” lines can directly drive a **16Ω load** at -12dBFS (\*\*\*) in *Differential* configuration
- the “*Ear\_HF*” lines can directly drive a **4Ω load** in *Differential* configurations
- There is no difference if the amplifiers drive an external amplifier

(\*\*) *OdBFS* is the normalized overall Analog Gain for each Output channel equal to  $3,7V_{pp}$  differential

“EAR_MT” Output Lines	
line coupling	AC single-ended DC differential
0dBFS normalized gain	3,7 V <sub>pp</sub> differential
output load resistance	≥ 16 Ω @ -12dBFS
internal output resistance	4Ω (typical)
signal bandwidth	150 - 4000 Hz @ -3 dB



**GE/GC864-QUAD V2 and GE864-GPS Hardware User Guide**

1vv0300915 Rev.2 – 2011-06-15

maximal full scale differential output voltage	3,7 V <sub>pp</sub> (typical) R <sub>load</sub> =open circuit
differential output voltage	925mV <sub>pp</sub> / R <sub>load</sub> =16Ω @ -12dBFS
volume increment	2 dB per step
volume steps	10

"EAR_HF" Output Lines	
line coupling	AC single-ended DC differential
output load resistance	≥ 8 Ω
signal bandwidth	150 - 4000 Hz @ -3 dB
maximal output power @ battery voltage ≥ 3,6V	0.35 W <sub>rms</sub> / 8 Ω
volume increment	2 dB per step
volume steps	10



## 11. General Purpose I/O

The general-purpose I/O pads can be configured to act in three different ways:

- Input
- Output
- Alternate function (internally controlled)

Input pads can only be read and report the digital value (high or low) present on the pad at the read time; output pads can only be written or queried and set the value of the pad output; an alternate function pad is internally controlled by the GE/GC864-QUAD V2 and GE864-GPS firmware and acts depending on the function implemented.

The following GPIO are available on the GE/GC864-QUAD V2 and GE864-GPS:

Ball GE864	Pin GC864	Signal	I/O	Function	Type	Input / output current	Default state	ON_OF F state	During Reset state	Note
C1	70	TGPIO_01	I/O	GPIO01 Configurable GPIO	CMOS 2.8V	1uA / 1mA	INPUT	0	0	
E6	74	TGPIO_02 / JDR	I/O	GPIO02 Configurable GPIO	CMOS 2.8V	1uA / 1mA	INPUT	0	0	Alternate function (JDR)
C2	66	TGPIO_03	I/O	GPIO03 Configurable GPIO	CMOS 2.8V	1uA / 1mA	INPUT	0	0	
B3	59	TGPIO_04 / TXCNTRL	I/O	GPIO04 Configurable GPIO	CMOS 2.8V	1uA / 1mA	INPUT	0	0	Alternate function (RF Transmission Control)
K8	78	TGPIO_05 / RFTXMON	I/O	GPIO05 Configurable GPIO	CMOS 2.8V	1uA / 1mA	INPUT	0	0	Alternate function (RFTXMON)
B5	68	TGPIO_06 / ALARM	I/O	GPIO06 Configurable GPIO	CMOS 2.8V	1uA / 1mA	INPUT	0	0	Alternate function (ALARM)
L9	73	TGPIO_07 / BUZZER	I/O	GPIO07 Configurable GPIO	CMOS 2.8V	1uA / 1mA	INPUT	0	0	Alternate function (BUZZER)
K11	67	TGPIO_08	I/O	GPIO08 Configurable GPIO	CMOS 2.8V	1uA / 1mA	INPUT	0	0	
C9	76	TGPIO_09	I/O	GPIO09 Configurable GPIO	CMOS 2.8V	1uA / 1mA	INPUT	0	0	
H3	63	TGPIO_10 / DVI_TX	I/O	GPIO10 Configurable GPIO	CMOS 2.8V	1uA / 1mA	INPUT	0	0	Alternate function (DVI_TX)

Not all GPIO pads support all these three modes:

- GPIO2 supports all three modes and can be input, output, Jamming Detect Output (Alternate function)
- GPIO4 supports all three modes and can be input, output, RF Transmission Control (Alternate function)
- GPIO5 supports all three modes and can be input, output, RFTX monitor output (Alternate function)
- GPIO6 supports all three modes and can be input, output, alarm output (Alternate function)
- GPIO7 supports all three modes and can be input, output, buzzer output (Alternate function)



## 11.1. GPIO Logic Levels

Where not specifically stated, all the interface circuits work at 2.8V CMOS logic levels. The following tables show the logic level specifications used in the GE/GC864-QUAD V2 and GE864-GPS interface circuits:

### Absolute Maximum Ratings –Not Functional

Parameter	Min	Max
Input level on any digital pin when on	-0.3V	+3.1V
Input voltage on analog pins when on	-0.3V	+3.0 V

### Operating Range – Interface Levels (2.8V CMOS)

Level	Min	Max
Input high level	2.1V	3.1V
Input low level	0V	0.5V
Output high level	2.2V	3.0V
Output low level	0V	0.35V

## 11.2. Using a GPIO Pad as INPUT

The GPIO pads, when used as inputs, can be connected to a digital output of another device and report its status, provided this device has interface levels compatible with the 2.8V CMOS levels of the GPIO.

If the digital output of the device to be connected with the GPIO input pad has interface levels different from the 2.8V CMOS, then it can be buffered with an open collector transistor with a 47K pull up to 2.8V, this pull up must be switched off when the module is in off condition.

## 11.3. Using a GPIO Pad as OUTPUT

The GPIO pads, when used as outputs, can drive 2.8V CMOS digital devices or compatible hardware. When set as outputs, the pads have a push-pull output and therefore the pull-up resistor may be omitted.



The illustration below shows the base circuit of a push-pull stage:

## 11.4. Using the RF Transmission Control GPIO4

The GPIO4 pin, when configured as RF Transmission Control Input, permits to disable the Transmitter when the GPIO is set to Low by the application. In the design is necessary to add a resistor 47K pull up to 2.8V, this pull up must be switched off when the module is in off condition.

## 11.5. Using the RFTXMON Output GPIO5

The GPIO5 pin, when configured as RFTXMON Output, is controlled by the GE/GC 864 QUAD V2 module and will rise when the transmitter is active and fall after the transmitter activity is completed.

There are 2 different modes for this function:

- 1) Active during all the calls:

For example, if a call is started, the line will be HIGH during all the conversation and it will

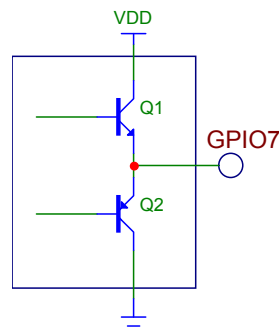

be again LOW after hanged up.

The line rises up 300ms before first TX burst and will became again LOW from 500ms to 1s after last TX burst.

- 2) Active during all the TX activity:

The GPIO is following the TX bursts

Please refer to the AT User interface manual for additional information on how to enable this function.

## 11.6. Using the Alarm Output GPIO6

The GPIO6 pad, when configured as Alarm Output, is controlled by the module and will rise when the alarm starts and fall after the issue of a dedicated AT command.



This output can be used to power up the module controlling micro controller or application at the alarm time, giving you the possibility to program a timely system wake-up to achieve some periodic actions and completely turn off either the application and the module during sleep periods, dramatically reducing the sleep consumption to few  $\mu\text{A}$ . In battery-powered devices this feature will greatly improve the autonomy of the device.



**NOTE:**

During RESET the line is set to HIGH logic level.

## 11.7. Using the Buzzer Output GPIO7

The GPIO7 pad, when configured as Buzzer Output, is controlled by the GE/GC 864 QUAD V2 module and will drive with appropriate square waves a Buzzer driver. This permits to your application to easily implement Buzzer feature with ringing tones or melody played at the call incoming, tone playing on SMS incoming or simply playing a tone or melody when needed by your application.

A sample interface scheme is included below to give you an idea of how to interface a Buzzer to the GPIO7:

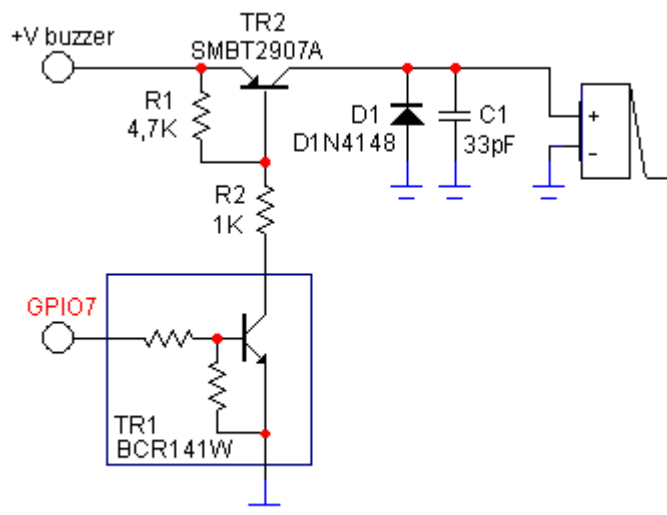



**NOTE:**

To correctly drive a buzzer a driver must be provided, its characteristics depend on the Buzzer and for them refer to your buzzer vendor.

## 11.8. Using the Temperature Monitor Function

### 11.8.1. Short Description

The Temperature Monitor is a function of the module that permits to control its internal temperature and if properly set (see the #TEMPMON command on AT Interface guide) it raise to High Logic level a GPIO when the maximum temperature is reached.

### 11.8.2. Allowed GPIO

The AT#TEMPMON set command could be used with one of the following GPIO:

Ball GE864	Pin GC864	Signal	I/O	Function	Type	Input / output current	Default state	ON_OF F state	During Reset state	Note
C1	70	TGPIO_01	I/O	GPIO01 Configurable GPIO	CMOS 2.8V	1uA / 1mA	INPUT	0	0	
E6	74	TGPIO_02 / JDR	I/O	GPIO02 Configurable GPIO	CMOS 2.8V	1uA / 1mA	INPUT	0	0	Alternate function (JDR)
C2	66	TGPIO_03	I/O	GPIO03 Configurable GPIO	CMOS 2.8V	1uA / 1mA	INPUT	0	0	
B3	59	TGPIO_04 / TXCNTRL	I/O	GPIO04 Configurable GPIO	CMOS 2.8V	1uA / 1mA	INPUT	0	0	Alternate function (RF Transmission Control)
K8	78	TGPIO_05 / RFTXMON	I/O	GPIO05 Configurable GPIO	CMOS 2.8V	1uA / 1mA	INPUT	0	0	Alternate function (RFTXMON)
B5	68	TGPIO_06 / ALARM	I/O	GPIO06 Configurable GPIO	CMOS 2.8V	1uA / 1mA	INPUT	0	0	Alternate function (ALARM)
L9	73	TGPIO_07 / BUZZER	I/O	GPIO07 Configurable GPIO	CMOS 2.8V	1uA / 1mA	INPUT	0	0	Alternate function (BUZZER)
K11	67	TGPIO_08	I/O	GPIO08 Configurable GPIO	CMOS 2.8V	1uA / 1mA	INPUT	0	0	
C9	76	TGPIO_09	I/O	GPIO09 Configurable GPIO	CMOS 2.8V	1uA / 1mA	INPUT	0	0	
H3	63	TGPIO_10 / DVI_TX	I/O	GPIO10 Configurable GPIO	CMOS 2.8V	1uA / 1mA	INPUT	0	0	Alternate function (DVI_TX)







**NOTE:**

If the set command is enable the alternate function is not usable.

## 11.9. Indication of Network Service Availability

The STAT\_LED pin status shows information on the network service availability and Call status.

In the GE/GC864-QUAD V2 and GE864-GPSmodules, the STAT\_LED usually needs an external transistor to drive an external LED.

Therefore, the status indicated in the following table is reversed with respect to the pin status.

LED status	Device Status
Permanently off	Device off
Fast blinking (Period 1s, Ton 0,5s)	Net search / Not registered / turning off
Slow blinking (Period 3s, Ton 0,3s)	Registered full service
Permanently on	a call is active

A schematic example could be:

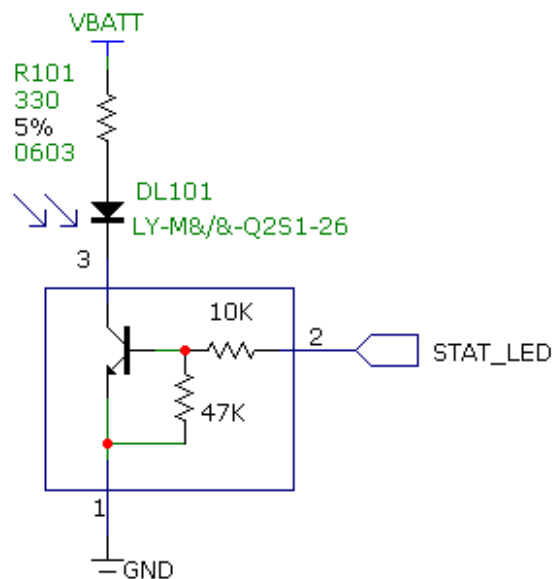

## 11.10. RTC Bypass Out

The VRTC pin brings out the Real Time Clock supply, which is separate from the rest of the digital part, allowing having only RTC going on when all the other parts of the device are off. To this power output a backup capacitor can be added in order to increase the RTC autonomy during power off of the battery. NO Devices must be powered from this pin.

## 11.11. External SIM Holder Implementation

Please refer to the related User Guide (SIM Holder Design Guides, 80000NT10001a).

## 11.12. VAUX Power Output (only for GE864-GPS)

A regulated power supply output is provided in order to supply small devices from the module.

This output is always active when the module is powered by VBATT.

The operating range characteristics of the supply are:

### Operating Range – VAUX1 power supply

	Min	Typical	Max
<b>Output voltage</b>	2.74V	2.80V	2.86V
<b>Output current</b>			100mA
<b>Output bypass capacitor (inside the module)</b>			1µF



## 12. GPS Features (only GE864-GPS)

### 12.1. GPS Control

The GPS part of GE864-GPS can be driven by the GSM engine or by an external host. The circuitual connections of the two configurations are showed in the subparagraphs below.

#### 12.1.1. GSM Controlled Mode

The GPS part can be controlled by GSM part through specific AT commands (refer to AT\$GPSAT on AT Commands Reference Guide, 80000ST10025a). The required electrical connections are showed in the figure below.

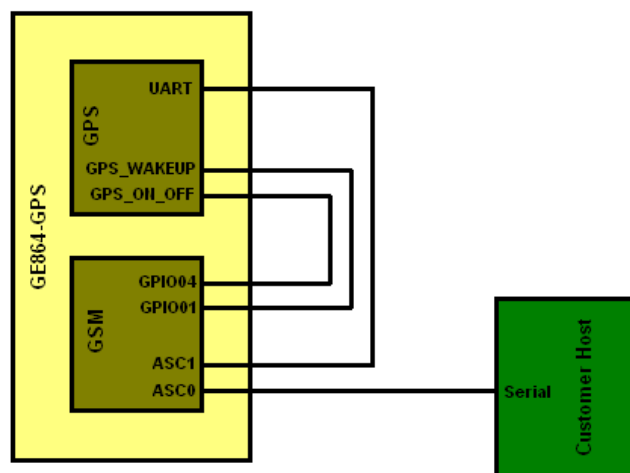

#### 12.1.2. External Host Controlled Mode

Alternatively to the previous configuration, the GPS part can be controlled by an external Host so the GSM and GPS may be managed separately. In this case the Host must have at least two serial ports and two GPIO available for the control of GPS (see the figure below).



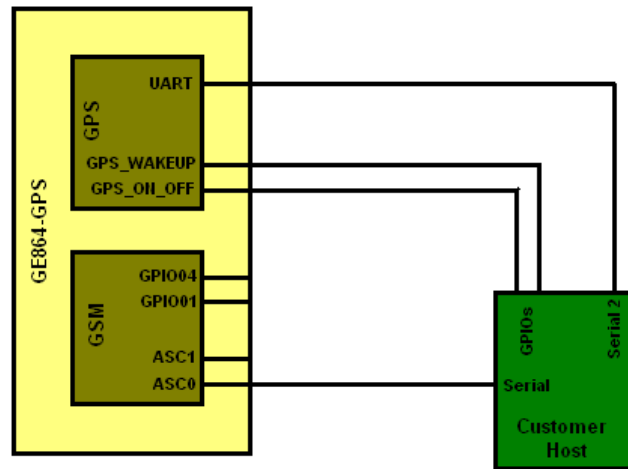

## 12.2. PPS GPS Output

### 12.2.1. Description

The Time Mark output GPS\_PPS provides a one pulse-per-second signal to the user specific application. The GPS\_PPS pulse is available at any time as soon as a fix is done. This signal is a positive logic, CMOS level output pulse that transitions from logic 'low' condition to logic 'high' at a 1 Hz rate.

### 12.2.2. Pulse Characteristics

The signal is available on BGA Ball C8 on GE864-GPS and on pin 24 of PL101 on EVK2 Adapter board.

Type: Output CMOS 1.8V  
Duration: Typically 1us



**NOTE:**

The signal is available only when the receiver provides a valid Navigation solution.



## 13. DAC and ADC Converter

### 13.1. DAC Converter

#### 13.1.1. Description

Ball GE864	Pin GC864	Signal	I/O	Function
DAC Converter				
C7	40	DAC_OUT	AO	Digital/Analog converter output

The GE/GC864-QUAD V2 AND GE864-GPSmodules provide one Digital to Analog Converter.

The on board DAC is a 10-bit converter, able to generate an analogue value based a specific input in the range from 0 up to 1023. However, an external low-pass filter is necessary.

	Min	Max	Units
Voltage range (filtered)	0	2,6	Volt
Range	0	1023	Steps

The precision is 10 bits, so if we consider that the maximum voltage is 2V, the integrated voltage could be calculated with the following formula:

$$\text{Integrated output voltage} = 2 * \text{value} / 1023$$

DAC\_OUT line must be integrated (for example with a low band pass filter) in order to obtain an analog voltage.

#### 13.1.2. Enabling DAC

The AT command below is available to use the DAC function:

**AT#DAC[=<enable>[,<value>]]**

<value> – scale factor of the integrated output voltage (0–1023, with 10 bit precision), and it must be present if <enable>=1.

Refer to SW User Guide or AT Commands Reference Guide for the full description of this function.

Refer to SW User Guide or AT Commands Reference Guide for the full description of this function.





**NOTE:**

The DAC frequency is selected internally. D/A converter must not be used during POWERSAVING.

### 13.1.3. Low Pass Filter Example

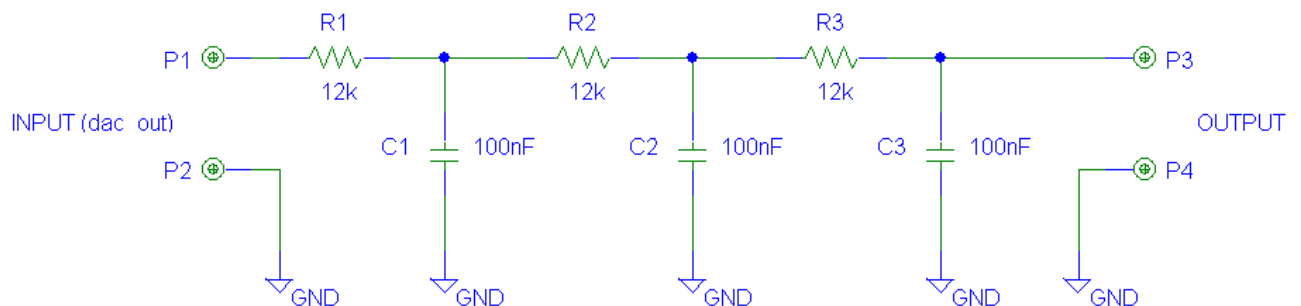

## 13.2. ADC Converter

### 13.2.1. Description

Ball GE864	Pin GC864	Signal	I/O	Function
<b>ADC Converters</b>				
J11	37	ADC_IN1	AI	Analog/Digital converter input
H11	38	ADC_IN2	AI	Analog/Digital converter input
N/A*	39	ADC_IN3	AI	Analog/Digital converter input

The GE/GC864-QUAD V2 AND GE864-GPSmodules provide three\* (only two in GE864-QUAD V2) Analog to Digital Converter.

The on board A/D are 11-bit converter. They are able to read a voltage level in the range of 0÷2 volts applied on the ADC pin input, store and convert it into 11 bit word.



	<b>Min</b>	<b>Max</b>	<b>Units</b>
Input Voltage range	0	2	Volt
AD conversion	-	11	bits
Resolution	-	< 1	mV

### 13.2.2. Using ADC Converter

The AT command below is available to use the ADC function:

**AT#ADC=1,2**

The read value is expressed in mV.

Refer to SW User Guide or AT Commands Reference Guide for the full description of this function.



## 14. Assembly the GE/GC864-QUAD V2 AND GE864-GPS on the Board

### 14.1. Assembly the GE864-QUAD V2

The Telit GE864-QUAD V2 have been designed in order to be compliant with the standard lead-free SMT process.

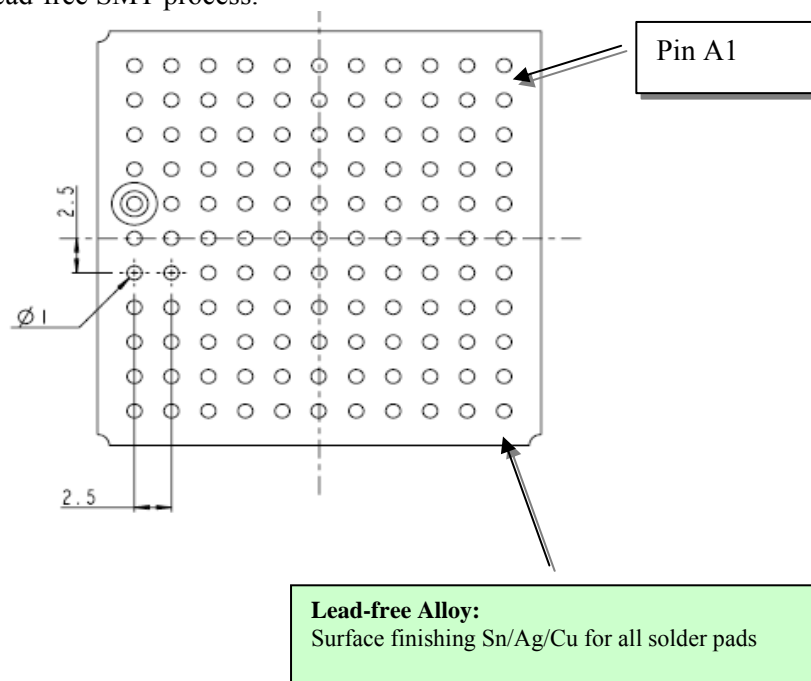

#### 14.1.1. Recommended foot print for the application

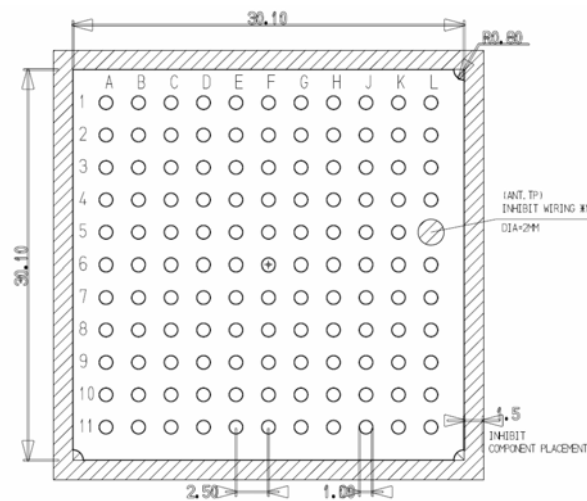





**NOTE:**

In order to easily rework the GE864-QUAD V2 module is suggested to consider on the application a 1.5mm inhibit area around the module.

It is also suggested, as common rule for a SMT component, to avoid having a mechanical part of the application in direct contact with the module.

### 14.1.2. Stencil

Stencil apertures layout can be the same of the recommended footprint (1:1), we suggest a thickness of stencil foil >120µm.

### 14.1.3. PCB pad design

Non solder mask defined” (NSMD) type is recommended for the solder pads on the PCB.

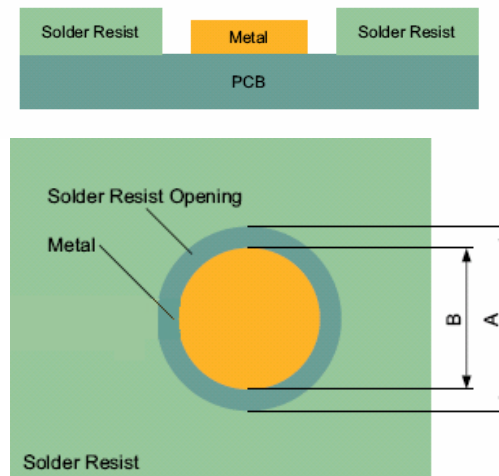

Recommendations for PCB pad dimensions

Ball pitch [mm]	2,4
Solder resist opening diameter A [mm]	1,150
Metal pad diameter B [mm]	1 ± 0.05

It is recommended no microvia without solder resist cover under the module and no microvia around the pads (see following figure).



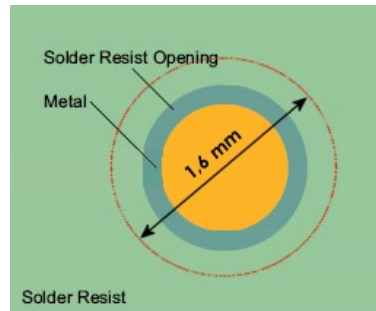

Holes in pad are allowed only for blind holes and not for through holes.

Recommendations for PCB pad surfaces:

<b>Finish</b>	<b>Layer thickness [<math>\mu\text{m}</math>]</b>	<b>Properties</b>
Electro-less Ni / Immersion Au	3 – 7 / 0.05 – 0.15	good solder ability protection, high shear force values

The PCB must be able to resist the higher temperatures which are occurring at the lead-free process. This issue should be discussed with the PCB-supplier. Generally, the wettability of tin-lead solder paste on the described surface plating is better compared to lead-free solder paste.

#### 14.1.4. Solder paste

	<b>Lead free</b>
<b>Solder paste</b>	Sn/Ag/Cu

It is recommended to use only “no clean” solder paste in order to avoid the cleaning of the modules after assembly.

#### 14.1.5. GE864-QUAD V2/GPS Solder reflow

The following is the recommended solder reflow profile



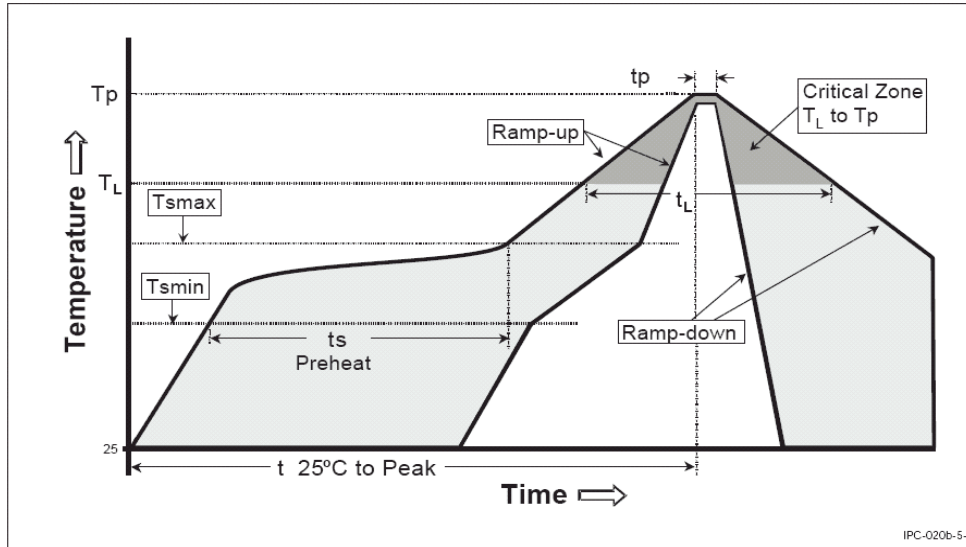

IPC-020b-5-1

Profile Feature	Pb-Free Assembly
Average ramp-up rate ( $T_L$ to $T_P$ )	3°C/second max
Preheat <ul style="list-style-type: none"> <li>- Temperature Min (<math>T_{smin}</math>)</li> <li>- Temperature Max (<math>T_{smax}</math>)</li> <li>- Time (min to max) (<math>t_s</math>)</li> </ul>	150°C 200°C 60-180 seconds
$T_{smax}$ to $T_L$ <ul style="list-style-type: none"> <li>- Ramp-up Rate</li> </ul>	3°C/second max
Time maintained above: <ul style="list-style-type: none"> <li>- Temperature (<math>T_L</math>)</li> <li>- Time (<math>t_L</math>)</li> </ul>	217°C 60-150 seconds
Peak Temperature ( $T_p$ )	245 +0/-5°C
Time within 5°C of actual Peak Temperature ( $t_p$ )	10-30 seconds
Ramp-down Rate	6°C/second max.
Time 25°C to Peak Temperature	8 minutes max.



**NOTE:**

All temperatures refer to topside of the package, measured on the package body surface



**WARNING:**

The GE865 module withstands one reflow process only.



## 14.2. Assembly the GC864-QUAD V2

The position of the Molex board to board connector and the pin 1 are shown in the following picture.

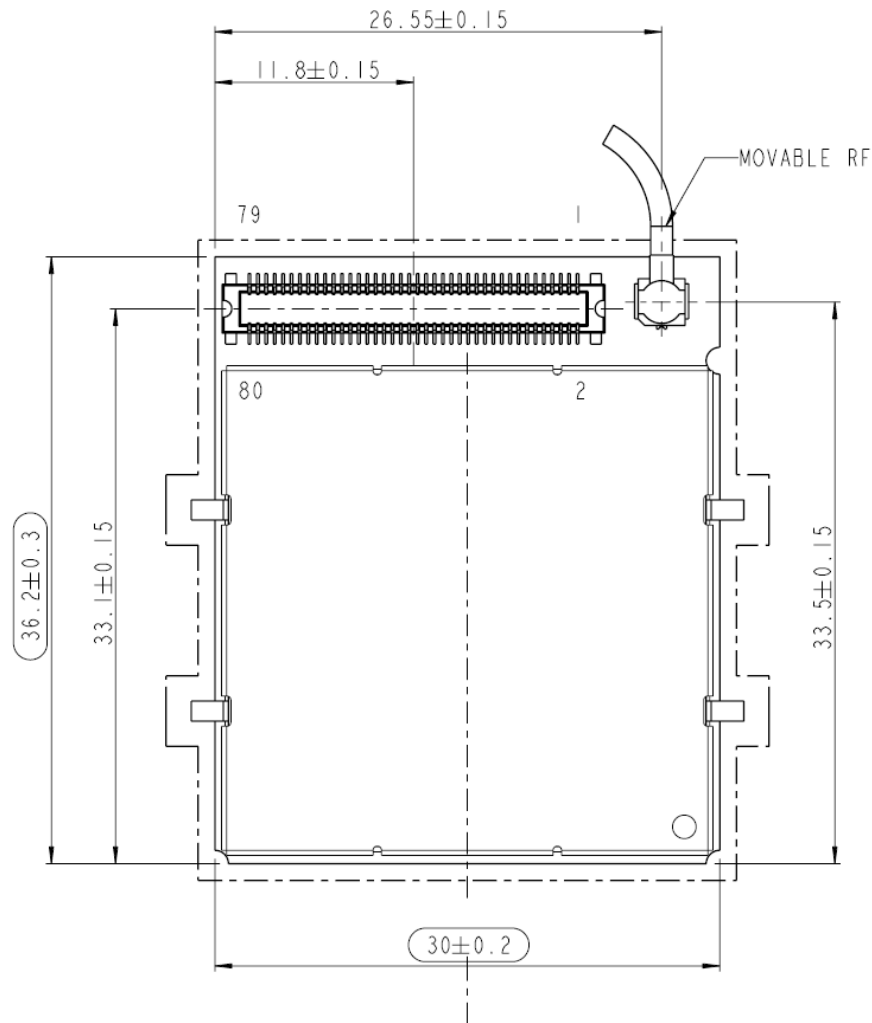

### NOTE:

The metal tabs present on GC864-QUAD V2 must be connected to GND.  
This module could not be processed with a reflow.



### 14.3. Debug of the GE/GC864-QUAD V2 AND GE864-GPS in Production

To test and debug the mounting of GC/GE864-QUAD V2 and GE864-GPS, we strongly recommend to foreseen test pads on the host PCB, in order to check the connection between the GE/GC864-QUAD V2 and GE864-GPS itself and the application and to test the performance of the module connecting it with an external computer. Depending by the customer application, these pads include, but are not limited to the following signals:

Ball GE864	Pin GC864	Signal	Function
J1, J2, K1, K2	1,2,3,4	VBATT	Main power supply
A1, A11, D6, F1, F11, H1, H2, J3, K3, K4, K5, K6, L1, L2, L3, L6, L11	5,6,7,46	GND	Ground
E7	25	C103/TXD	Serial data input (TXD) from DTE
H8	26	C104/RXD	Serial data output (RXD) to DTE
L8	49	PRWMON	Power ON Monitor
J5	53	ON/OFF*	Input command for switching power ON or OFF (toggle command).
A2	54	RESET*	Reset input
F10	23	RX_AUX	Auxiliary UART (RX Data from DTE)
D11	24	TX_AUX	Auxiliary UART (TX Data to DTE)
H4	47	SERVICE	Service pin shall be used to upgrade the module from ASC1 (RX_TRACE, TX_TRACE). The pin shall be tied low to enable the feature only in case of a SW Update activity. It is required, for debug purpose, to be connected to a test pad on the final application.
J4 <sup>3</sup>	N/A	GPS_ON_OFF <sup>3</sup>	GPS Power Control
E10 <sup>3</sup>	N/A	GPS_RX <sup>3</sup>	GPS Serial data input
F8 <sup>3</sup>	N/A	GPS_TX <sup>3</sup>	GPS Serial data output
G2 <sup>3</sup>	N/A	GPS_WAKEUP <sup>3</sup>	Wake up output <sup>3</sup>

(  
3) Available only on GE864-GPS (in case of GE864-QUAD it has to be considered RESERVED)



## 15. Packing system

### 15.1. GE864-QUAD V2/GPS Packaging

The GE864-QUAD V2/GPS is packaged on trays of **20** pieces each. This is especially suitable for the GE864-QUAD V2/GPS according to SMT processes for pick & place

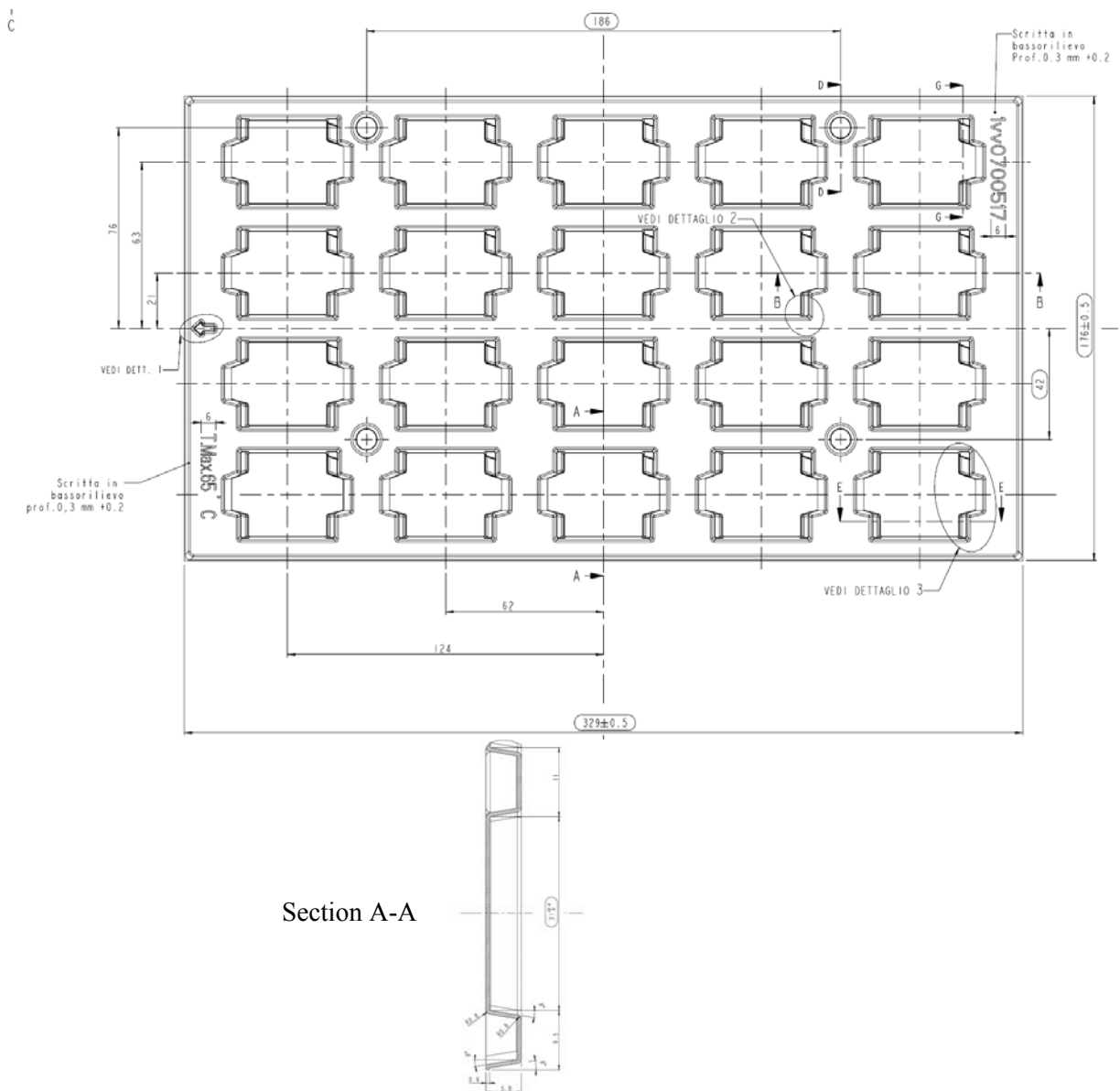

movement requirements. The size of the tray is: 329 x 176mm.





**WARNING:**

These trays can withstand at the maximum temperature of 65° C.



**NOTE:**

All temperatures refer to topside of the package, measured on the package body surface

**15.1.1. Moisture sensibility**

The level of moisture sensibility of GE864-QUAD V2/GPS is “3”, in according with standard IPC/JEDEC J-STD-020, take care all the relatives requirements for using this kind of components.

**15.1.2. GE864 orientation on the tray**

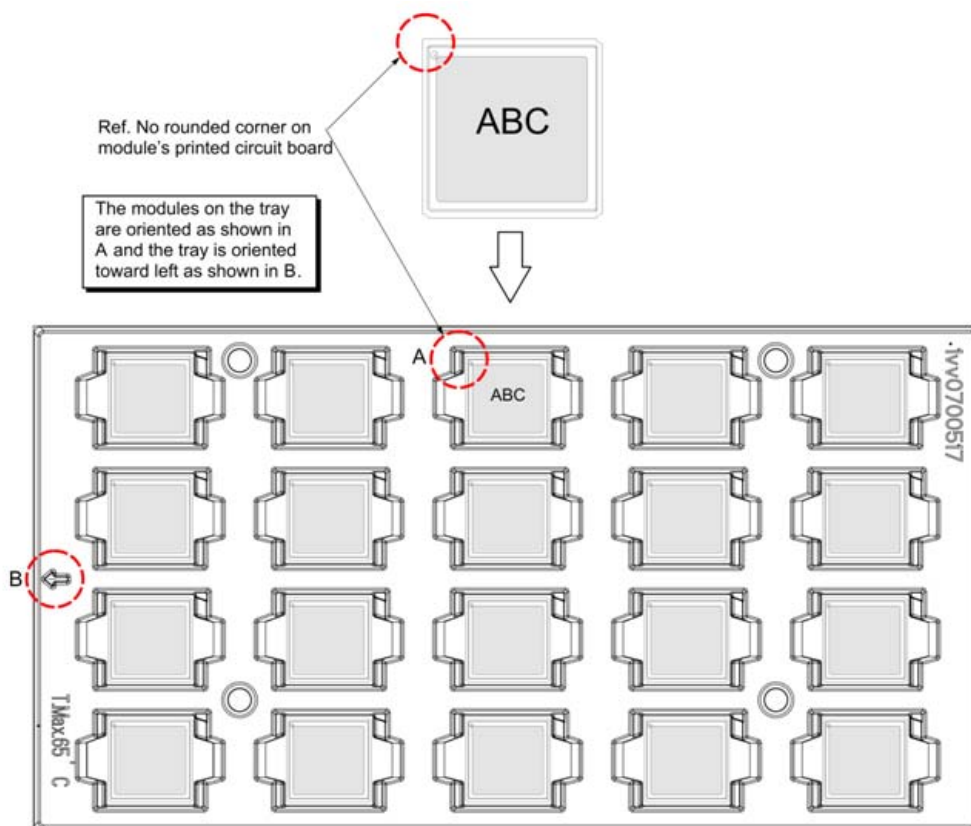

## 15.2. GE/GC864-QUAD V2 AND GE864-GPS Packaging

The Telit GC864-QUAD V2 are packaged on trays of 20 pieces each.

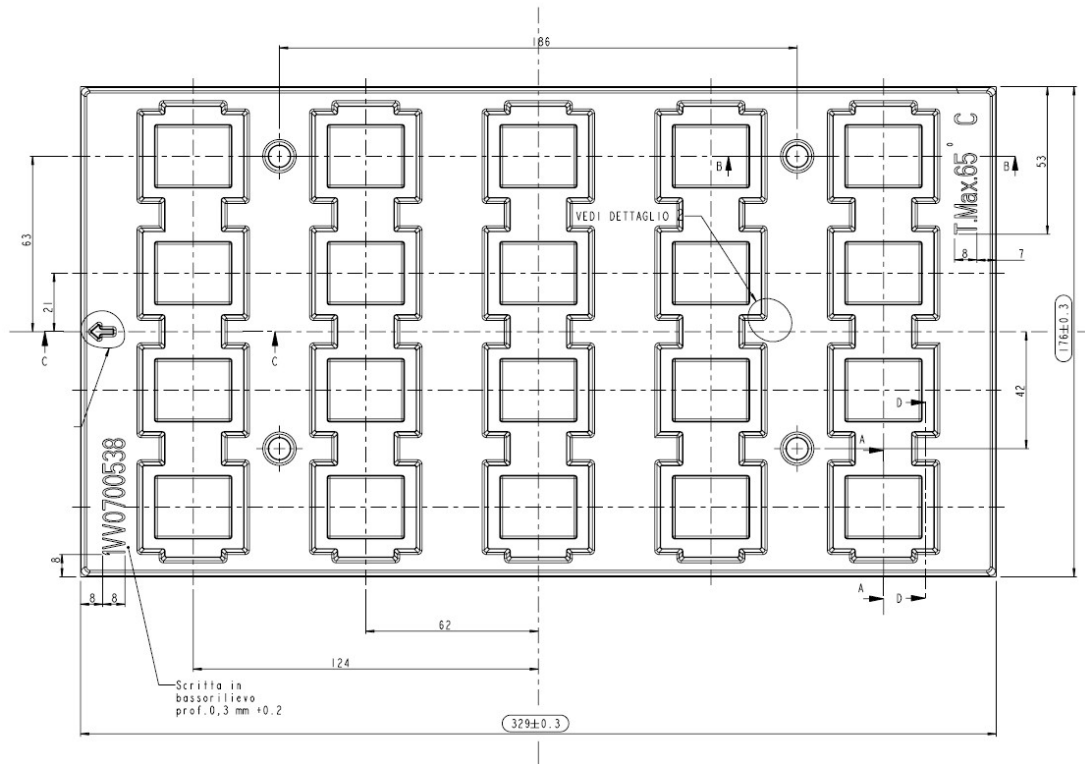

size of the tray is: 329 x 176mm.



### WARNING:

These trays can withstand at the maximum temperature of 65° C.





## 16. Conformity Assessment Issues



The Telit GE/GC864-QUAD V2 and GE864-GPS has been assessed in order to satisfy the essential requirements of the R&TTE Directive 1999/05/EC (Radio Equipment & Telecommunications Terminal Equipments) to demonstrate the conformity against the harmonized standards with the final involvement of a Notified Body.

If the module is installed in conformance to the Telit installation manuals, no further evaluation under **Article 3.2** of the R&TTE Directive and do not require further involvement of a R&TTE Directive Notified Body for the final product.

In all other cases, or if the manufacturer of the final product is in doubt, then the equipment integrating the radio module must be assessed against **Article 3.2** of the R&TTE Directive.

In all cases the assessment of the final product must be made against the Essential requirements of the R&TTE Directive **Articles 3.1(a)** and **(b)**, Safety and EMC respectively, and any relevant Article 3.3 requirements.

This Hardware User Guide contains all the information you may need for developing a product meeting the R&TTE Directive.

Furthermore the GE/GC864-QUAD V2 AND GE864-GPSmodules are FCC Approved as module to be installed in other devices. This device is to be used only for fixed and mobile applications. If the final product after integration is intended for portable use, a new application and FCC is required.

The GE/GC864-QUAD V2 AND GE864-GPSare conforming to the following US Directives:

- Use of RF Spectrum. Standards: FCC 47 Part 24 (GSM 1900)
- EMC (Electromagnetic Compatibility). Standards: FCC47 Part 15

This device complies with Part 15 of the FCC Rules. Operation is subject to the following two conditions:

- (1) this device may not cause harmful interference, and
- (2) this device must accept any interference received, including interference that may cause undesired operation.

To meet the FCC's RF exposure rules and regulations:

- The system antenna(s) used for this transmitter must be installed to provide a separation distance of at least 20 cm from all the persons and must not be co-located or operating in conjunction with any other antenna or transmitter.



**GE/GC864-QUAD V2 and GE864-GPS Hardware User Guide**

1vv0300915 Rev.2 – 2011-06-15

- The system antenna(s) used for this module must not exceed 1.4dBi (850MHz) and 3.0dBi (1900MHz) for mobile and fixed or mobile operating configurations.
- Users and installers must be provided with antenna installation instructions and transmitter operating conditions for satisfying RF exposure compliance.

Manufacturers of mobile, fixed or portable devices incorporating this module are advised to clarify any regulatory questions and to have their complete product tested and approved for FCC compliance.



## 17. SAFETY RECOMMENDATIONS



---

### NOTE:

Read this section carefully to ensure the safe operation.

---

Be sure the use of this product is allowed in the country and in the environment required. The use of this product may be dangerous and has to be avoided in the following areas:  
Where it can interfere with other electronic devices in environments such as hospitals, airports, aircrafts, etc

Where there is risk of explosion such as gasoline stations, oil refineries, etc

It is responsibility of the user to enforce the country regulation and the specific environment regulation.

Do not disassemble the product; any mark of tampering will compromise the warranty validity.

We recommend following the instructions of the hardware user guides for a correct wiring of the product. The product has to be supplied with a stabilized voltage source and the wiring has to be conforming to the security and fire prevention regulations.

The product has to be handled with care, avoiding any contact with the pins because electrostatic discharges may damage the product itself. Same cautions have to be taken for the SIM, checking carefully the instruction for its use. Do not insert or remove the SIM when the product is in power saving mode.

The system integrator is responsible of the functioning of the final product; therefore, care has to be taken to the external components of the module, as well as of any project or installation issue, because the risk of disturbing the GSM network or external devices or having impact on the security. Should there be any doubt, please refer to the technical documentation and the regulations in force.

Every module has to be equipped with a proper antenna with specific characteristics. The antenna has to be installed with care in order to avoid any interference with other electronic devices and has to guarantee a minimum distance from the body (20 cm). In case of this requirement cannot be satisfied, the system integrator has to assess the final product against the SAR regulation EN 50360.

The European Community provides some Directives for the electronic equipments introduced on the market. All the relevant information's are available on the European Community website:

<http://ec.europa.eu/enterprise/sectors/rte/documents/>

The text of the Directive 99/05 regarding telecommunication equipments is available, while the applicable Directives (Low Voltage and EMC) are available at:

<http://ec.europa.eu/enterprise/sectors/electrical/>



## 18. Document History

<b>Revision</b>	<b>Date</b>	<b>Changes</b>
ISSUE#0	2011-01-14	First preliminary release
ISSUE#1	2011-04-07	Updated power consumption for GE864-GPS and ATEX data for GE864-GPS
ISSUE#2	2011-06-15	Updated Pin Out GE864 QUAD/GPS Added “5.4 Turning ON/OFF the GPS (only GE864-GPS)” paragraph Updated GPS Antenna Requirements Updated Logic Level Specifications Added “11.12 VAUX Power Output (only for GE864-GPS)” paragraph Added “12. GPS Features (GE864-GPS only)” Chapter

